

Carrier

TRANSICOLD

# 20 SERIES PERFORMANCE PARTS

2007 catalog



Build Carrier quality into your TK® unit.



This catalog has been developed to provide Carrier Transicold dealers and customers easy access to Carrier Transicold Performance Parts available for servicing TK<sup>®</sup> units.

You already know the benefits of using genuine Carrier replacement parts to service your Carrier units. That same tradition of quality, reliability, and warranty assurance is also available in an ever-expanding line of 20-Series parts for your TK units.

All 20-Series parts are specified by transport refrigeration engineers. They are then put through field trial testing prior to release to the dealer and end users to insure that fit, form and function meets OEM specifications.

20-Series parts come with a nationwide warranty backed by over 125 Carrier Transicold Truck/Trailer dealers and service centers throughout the U.S. and Canada. Contact your local dealer for details.

We are continuously adding new parts to our 20-Series product line, so if you don't see the part you are looking for in this catalog, contact your local Carrier Transicold dealer to see if it has been added.

This catalog is divided into two sections:

## **CROSS REFERENCE / WHERE USED**

Provides complete part number cross reference in numerical sequence by TK part number along with a where used for popular TK truck and trailer units.

## **PARTS BY COMMODITY**

Groups high-use parts by commodity (ie. compressors, engines, filters, belts, etc.) and then by TK part number. We have added many photos to this section for the convenience of identifying the part you need.

Thank you for your confidence in Carrier Transicold Performance Parts. If you have any questions regarding information in this catalog or are in need of further assistance, please contact **Performance Parts Customer Service at (800-255-7382).**

## Contents:

New Products.....	II - XVII
TK/Carrier Numeric Cross Reference & Where Used on TK.....	1-22
ALTERNATORS/REGULATORS.....	23-25
BELTS.....	26-28
CLUTCHES.....	29
COMPRESSORS	
Remanufactured Compressors...	30
Rebuild Kits.....	30-31
Gasket Kits / Rebuild Kits .....	31
Photos of Popular Parts.....	32-34
DOORS & ACCESSORIES.....	35
ELECTRICAL	
Photos of Components.....	36-39
ENGINES	
C201 Isuzu.....	40-42
2.2DI Isuzu.....	43-44
2.35 Yanmar.....	45
353 Yanmar.....	46
3.66 Yanmar.....	47
3.88 Yanmar.....	48
FILTERS.....	49-50
HOSES & VIBRASORBERS.....	51-52
REFRIGERATION PARTS.....	53-54
STARTERS.....	55
MISCELLANEOUS PARTS.....	56-57
WATER PUMPS.....	58
REBUILT ELECTRONICS.....	59

# Ryan<sup>®</sup> EZT Strip Chart Recorder

Carrier  
TRANSICOLD  
PERFORMANCE  
PARTS

## Features and Benefits

- Provides a permanent record of temperature in °F and °C
  - Offers proof that shipments or storage were within acceptable range
  - Detects fluctuations in temperature that may threaten the quality of products
- Pre-shipment validation to NIST standards
- Easy-to-use
  - Pre-sealed, ready to start
  - Strong adhesive backing tape for versatile mounting
- One-year shelf life
- The manufacturer provides free expert testimony regarding the operation, validation, and quality of the device in the event of a legal dispute between two parties

## A variety of recording lengths available!

- 5, 10, 20, 40 and 75-day versions
- Available at Carrier Transicold Dealers nationwide



**Simple. Reliable. Cost Effective.**

Carrier  
TRANSICOLD  
PERFORMANCE  
PARTS





# TempTale<sup>®</sup> Temperature & Humidity Monitors



## Maintain Precise Visibility of Your Cold Chain

### Features and Benefits

- Precision temperature and humidity monitors let you monitor and collect data about your temperature sensitive shipments
  - View current temperature reading and alarms continuously on the LCD display
  - Customize alarm settings to meet the widest array of in-transit and storage applications
  - Pre-program time and temperature limits to trigger “time-out-of-range” events
  - Collect up to 16,000 data points that can be easily downloaded to PC for detailed time/temperature history
- Maximum dependability for peace-of-mind
  - Provide proof that shipments or storage temperatures were within acceptable range
  - Detect fluctuations in temperature that may threaten the quality of products
- N.I.S.T. traceable validation certificate provided with each unit
- Portable, easily mounts to shipment or within storage area

### Multi-Use TempTale4 Monitor

- Accurately monitor temperature

### Multi-Use TempTale4 Humidity Monitor

- Accurately monitor temperature and relative humidity

- One-year limited warranty
- Available at Carrier Transicold Dealers nationwide



TempTale4 Monitor

TempTale4 Humidity Monitor

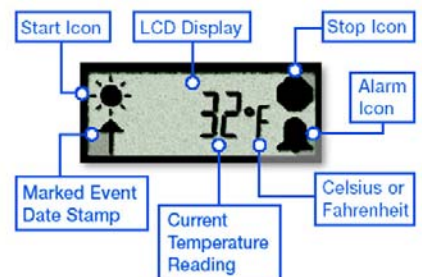

## TempTale® Manager Desktop Software

TempTale Manager Desktop is an easy-to-use, powerful PC-based Windows application for programming, downloading, displaying, analyzing and reporting time and temperature data from any TempTale monitor. The user-friendly interface provides superior flexibility when viewing, saving, printing and exporting monitor data.

### Features and Benefits

- Program both Primary and Secondary sensor alarms
- Automatically export data to Excel for further in-depth analysis or processing
- View numerous graphs simultaneously by overlaying graphs from multiple monitors to quickly highlight relationships
- Easily zoom-in on any segment of a Single or Multi-Graph view for a closer, more detailed display of a particular trip segment
- Software automatically computes key statistical information from multiple data files such as, Min, Max, Delta, Mean, Standard Deviation Temperature Values
- Automatically switch to a single data series view from a Multi-Graph view
- E-mail a saved file to a local or remote location or user
- Easily and quickly configure multi-use monitors to your specific application needs
- Automatically receive notification of software updates
- Request Technical Support and view Help Manual online
- Supported operating systems include: Windows 2000 and XP



### Data Security and Integrity

- Data files are saved as encrypted XML files and can only be read by the TTMD application
- Username and password is required to launch application
- System employs an automatic file-naming convention to link a printed and signed record to an electronic record
- System Administration rights required to setup new users, install application and assign user privileges
- Validated system with supporting Software Validation Package and documentation

### Interface Plus Reader

Sensitech's Interface Plus Reader allows a TempTale monitor to communicate with a PC using a standard RS232 serial connection to any free COM port.



# PowerRush™ High Cycle Battery

## Features and Benefits

- PowerRush 700 CCA High Cycle batteries have been tested and approved by Carrier Transicold engineers to meet the tough cycling demands of Transport Refrigeration applications.
- Lower Cost Per Mile
  - Maintenance free
  - Less downtime
- Longer Cycle Life
  - Massive cold start power
  - Engineered with extra cycling for greater energy reserve and longer life
- More Durable
  - Built in vibration resistance (exceeds the SAE standard)
  - Edge bonding keeps battery plates from moving
  - Ribbed casing and reinforced endwall design provides sturdy structure
  - Unmatched corrosion resistance
- Environmentally Friendly
  - Completely recyclable lead, plastics and acid
  - Fully protected against spillage and leaks
- 18 month free replacement warranty backed by Carrier Transicold Dealers nationwide



**Carrier Part Number: 30-50347**

Group	<b>31</b>
CCA	<b>700</b>
RC	<b>190</b>
Weight	<b>63.1 lbs</b>
SAEJ-2185 cycles	<b>442-468</b>
Anchor Bonded	<b>Yes</b>



# LED Light Bar

Carrier  
TRANSICOLD  
PERFORMANCE  
PARTS

## Features and Benefits

- Driver friendly
  - Auto dimming feature increases brightness in direct sunlight, snow and on white or reflective backgrounds
  - Dim at night for less glare and safer operation
  - Green light indicates “OK”, Amber means “Check Unit”. Amber follows the microprocessor fault light and alarms can be read on the micro display
- High visibility with wide viewing angle
  - Perfect for both driver’s mirror view, and long distance view on yard for distribution operations
- LED light bar provides lower lifecycle costs:
  - High-reliability, long-life LED arrays/no bulb replacements
  - Environmentally-sealed electronics/no opportunity for water intrusion
  - Low power design/80% current draw reduction from conventional product
- Can be used as a replacement for Carrier 8-light and Thermo King® light bars
- New low profile housing and lens design with UV protection
- Bracket mounted
- Covered by 1 year parts warranty
- Available at Carrier Transicold Dealers nationwide



Carrier  
TRANSICOLD  
PERFORMANCE  
PARTS

Carrier  
TRANSICOLD  
Turn to the Experts™

\*TK® is a registered trademark of Thermo King Corporation.



# Battery Separator Kit

## Dead Batteries Got You Down?

### Features and Benefits

- Prevents lift gate and other trailer accessories from draining reefer battery
  - When reefer battery voltage is above 13.2 volts it connects batteries in parallel allowing maximum operating performance for your lift gate and accessories
  - When voltage is below 12.7 volts it separates lift gate battery to preserve the unit battery
- Allows the reefer alternator to charge lift gate battery
- Provides additional battery protection when interior trailer lights are wired through the battery separator
- Meets the rugged demands of the transport refrigeration industry
  - Enclosed for safety and durability
  - Designed to operate at temperatures between -40°F to 180°F
  - Contains solid state circuitry which is protected from moisture and vibration
- Contains everything needed for a standard installation
- Easily installed on both Carrier Transicold and TK<sup>®</sup> units
- Available at Carrier Transicold Dealers nationwide



\*TK<sup>®</sup> is a registered trademark of Thermo King Corporation.

# Anti-Siphon Insert

Carrier  
TRANSICOLD  
PERFORMANCE  
PARTS

## Features and Benefits

- Provides low cost protection for your fuel investment
  - Offers immediate security against costly fuel theft
- Designed to easily fit into existing fuel tanks
  - Fits most tanks with a 2" diameter filler neck
  - Simple self-locking "snap in" installation
  - No hassling with keys and locking fuel caps
- Efficient 60 gallon-per-minute flow rate
- Readily available at Carrier Transicold Dealers nationwide



Carrier  
TRANSICOLD  
PERFORMANCE  
PARTS

Carrier  
TRANSICOLD  
Turn to the Experts

# Universal Bulkheads

Carrier  
TRANSICOLD  
PERFORMANCE  
PARTS

## Features and Benefits

- Patented design fits multiple trailer dimensions
  - Portable between trailers, reducing need to stock dedicated trailer bulkheads
  - No trailer measurements needed when ordering, will fit multiple trailer heights and widths
  - Eliminate down-time, order from inventory for quick repairs
- High quality construction provides superior performance
  - 2 piece, 2" design is light weight and installs in seconds
  - Equipped with long lasting stainless steel hardware
  - Reduces operating costs by providing a thermo efficient seal, even on older bowed trailers
- Backed by 90 day manufacturer warranty
- Readily available at Carrier Transicold Dealers nationwide



Carrier  
TRANSICOLD  
PERFORMANCE  
PARTS

Carrier  
TRANSICOLD  
Turn to the Experts

# Universal Rear Vinyl Curtain



## Features and Benefits

- Fuel Savings
  - Keeps air from escaping when door is open, resulting in faster recovery time and reduction in run hours of refrigeration unit
  - Can be moved up the trailer with a diminishing load to cool a smaller area and save you money
- Food Safety
  - Maintains the temperature of food products by keeping cold air in the trailer when the doors are open
  - Will protect dry compartment from extreme cold air in winter while rear door is open
- User Friendly
  - Easy to walk through, curtain can be strapped to side wall or removed from trailer during loading, unlike strip curtains which become wet & stiff
  - 2' x 3' clear window allows light to come through each side and allows driver to see through
- Light Weight
  - Curtain and track hardware weigh 48 lbs. and can be easily handled by one person
- USDA/FDA Approved
  - All materials are USDA/FDA approved. Chemicals used to clean out trailer will not damage curtain material
- Available at Carrier Transicold Dealers nationwide





# Return Air Bulkhead & Chutes



## Keep Your Load Cool – Without Blowing Your Budget

### Return Air Bulkhead

- Consistent Air Temperatures
  - Channels air evenly across trailer's full width to prevent hot and cold spots allowing for efficient operation of the refrigeration unit
- Continuous, Safeguarded Airflow
  - Innovative primary opening design and optional mesh screen provide a strong first line of defense ensuring maximum airflow even when trailer is fully loaded
- Fast, Simple Installation
  - Patented one-piece unit, with integrated pallet stops, installs in 15 minutes
- High Impact Resistance
  - Tough HMW polyethylene plastic stands up to extremely low temperatures and the rigorous demands of the road
  - Guaranteed not to crack, break or chip for three years
- USDA Approved for Food Transportation

### Chutes

- Complete line of ITW and Randall chutes and accessories
  - Available in vinyl, mesh or polyethylene
- Available at Carrier Transicold Dealers nationwide



Standard Specifications	
Material	HMW Polyethylene
Height	71.0'
Width	86.0'
Depth	4.5"
Weight	47 lbs.
Tensile Strength	3600 psi
Tensile Impact	170 ft lb/in <sup>3</sup>



# ComfortPro™ Plating Kits

Carrier  
TRANSICOLD  
PERFORMANCE  
PARTS

**Comfort Designed for the Eyes. Envy Guaranteed.**

## Features and Benefits

- Plating options guaranteed to make your auxiliary power unit the envy of the road.
- Designed for Easy Installation
  - Light weight
  - Mounts easily on new & existing ComfortPro units
  - Compatible with ProHeat® Gen 4 APU units
- **Chrome Plate Kit**
  - 430 stainless steel
  - Good corrosion resistance
  - Part number CP100
- **Diamond Plate Kit**
  - Perfect match with current exterior door
  - Highly durable aluminum diamond tread plating
  - Part number CP200
- Available at Carrier Transicold Dealers nationwide



**Chrome Plate**



**Diamond Plate**

Carrier  
TRANSICOLD  
PERFORMANCE  
PARTS

Carrier  
TRANSICOLD  
Turn to the Experts

# Microvac II Refrigerant Recovery Unit

Carrier  
TRANSICOLD  
PERFORMANCE  
PARTS

## Fast and Easy Refrigerant Recovery

### Features and Benefits

- Fast
  - Larger ¾ hp oil free compressor
  - Fastest direct liquid recovery rates
  - 30% faster recovery rates vs. PerformanceVac
  
- Durable
  - Longer service life, 10-inch vacuum switch halts recovery to prevent unit from prematurely wearing out components
  - Special discharge ball valve – prevents slugging and premature compressor failure
  - Double wall plastic housing absorbs shock and abrasions, weighs only 30 lbs.
  
- Easy to Operate
  - Two hand valves perform self-evacuation and recovery in fewer steps
  - Automatically stops vapor recovery when recovery process is complete
  - Overhaul compressor in the field in 30 minutes
  
- Available at Carrier Transicold Dealers nationwide



Carrier  
TRANSICOLD  
PERFORMANCE  
PARTS

Carrier  
TRANSICOLD  
Turn to the Experts

# Refrigerant Reclaim Units

	<b>BV-300 Series</b> Reclaimer	<b>JV-90 Series</b> Reclaimer	<b>LV-30 Series</b> Reclaimer	<b>CV-15 Series</b> Reclaimer	<b>RV-10 Series</b> Recovery Unit	<b>VS-29 Series</b> Deep Vacuum
						
<b>Dimensions</b>	Just Right For Industrial Use	Self-Cleaning Option Available Ideal For In-Shop Work	Perfect For Facility Maintenance & Manufacturing	Designed For Extra Mobility	Unbeatable For Rapid & Numerous Changing of Refrigerants	Great For Pulling To Deep Vacuum Levels
<b>Width</b>	42 in. / 106.7 cm	28 in. / 71.1 cm	24 in. / 61.0 cm	28 in. / 71.1 cm	15 in. / 38.1 cm	20 in. / 50.8 cm
<b>Depth</b>	24 in. / 61.0 cm	24 in. / 61.0 cm	16 in. / 40.6 cm	24 in. / 61.0 cm	18.5 in. / 46.9 cm	23.5 in. / 59.7 cm
<b>Height</b>	60 in. / 152.4 cm	60 in. / 152.4 cm	41 in. / 104.1 cm	45 in. / 114.3 cm	24 in. / 60.9 cm	33 in. / 83.8 cm
<b>Weight</b>	725 lbs. / 329 kg	460 lbs. / 209 kg	250 lbs. / 113 kg	223 lbs. / 101 kg	98 lbs. / 44.5 kg	90 lbs. / 40.8 kg
<b>Compressor</b>	2 Horsepower	2 Horsepower	1 Horsepower	1 Horsepower	1/2 Horsepower	1 Horsepower
<b>Electrical</b>	208/230, 60Hz, 1Ph	208/230, 60Hz, 1Ph	115/120, 60Hz, 1Ph	115/120, 60Hz, 1Ph	115/120, 60Hz, 1Ph	115/120, 60Hz, 1Ph
<b>Amperage</b>	20-amp service	20-amp service	15-amp service	15-amp service	10-amp service	10-amp service
<b>Reclaim Capacity</b>	5 lbs. / 2.3 kg Per Minute	5 lbs. / 2.3 kg Per Minute	3 lbs. / 1.4 kg Per Minute	3 lbs. / 1.4 kg Per Minute	1.2 lbs. / .5 kg Per Minute	Not Applicable
<b>Liquid</b>						
<b>On-board Storage</b>	300 lbs. / 136 kg	90 lbs. / 41 kg	30 lbs. / 14 kg	15 lbs. / 7 kg	None	None
<b>Valves</b>	1/4 in. / 6.3 mm SAE (3/8 in. Available)	1/4 in. / 6.3 mm SAE (3/8 in. Available)	1/4 in. / 6.3 mm SAE	1/4 in. / 6.3 mm SAE	1/4 in. / 6.3 mm SAE	1/4 in. / 6.3 mm SAE
<b>Cabinet</b>	Steel Powder Coat	Steel Powder Coat	Steel Powder Coat	Steel Powder Coat	Steel Powder Coat	Steel Powder Coat

## Refrigerants (Not all machines can handle all refrigerants):

R-12, R-22, R-134a, R-401A, R-401B, R-401C, R-402A, R-402B, R-404A, R-406A, R-407C, R-407D, R-408A, R-409A, R-410A, R-410B, R-411A, R-411B, R-412A, R-414A, R-414B, R-416A, R-500, R-502, R-509 ... and more

## Additional Available Equipment:

**Sure Safe Storage Systems** (Pressure Vessels) ranging in size from 30 to 300 lbs. / 14 to 136 kg designed with safety and convenience in mind.

## Features Include:

- ⇒ Alternate & International Voltages Available
- ⇒ Designed for Years of Dependable Service
- ⇒ Exclusive Patented Liquid Injection
- ⇒ Manufactured to customer's specifications with options to handle R-12, R-22, R-500 & R-502 and all alternates in the same range with one machine utilizing a unique multiple thermal expansion valve design
- ⇒ Measurable Oil Out Of Equipment Being Serviced
- ⇒ Meets All EPA Certification Requirements
- ⇒ UL Approved
- ⇒ Unique Air-Out Purging Feature
- ⇒ Unsurpassed Separation Of Contaminant



# Refrigerant



## Features and Benefits

- Carrier Transicold Performance Parts can handle all your refrigerant needs
- All Carrier brand refrigerants are American manufactured and meet all ARI700 regulations
- Competitively priced for incredible savings



- For more information about Transicold's refrigerant program and available refrigerants, contact your local Carrier Transicold Dealer

Refrigerant	Container lbs / Type
<b>R-22</b>	125 lb / returnable 50 lb / disposable 30 lb / disposable
<b>R-134a</b>	125 lb / returnable 30 lb / disposable
<b>R-404A</b>	100 lb / returnable 24 lb / disposable
<b>R-401A</b>	125 lb / returnable 30 lb / disposable
<b>R-401B</b>	125 lb / returnable 30 lb / disposable
<b>R-402A</b>	110 lb / returnable 27 lb / disposable
<b>R-407C</b>	25 lb / disposable
<b>R-408A</b>	100 lb / returnable 24 lb / disposable
<b>R-409A</b>	125 lb / returnable 30 lb / disposable
<b>R-502</b>	125 lb / returnable 50 lb / disposable 30 lb / disposable
<b>R-12</b>	145 lb / returnable 50 lb / disposable 30 lb / disposable
<b>R-500</b>	125 lb / returnable 30 lb / disposable



# Coil Cleaners



## Features and Benefits

- Complete line of coil cleaners and chemicals for all transport refrigeration and air conditioning units

## Coil Cleaners

- Nu-brite, CalClean, Tri-power: Biodegradable acidic or alkaline based products are safe yet aggressive! Cleans condenser and evaporator coils restoring lost capacity and operating efficiencies

## Coil Protection

- Cal-Shield: Cleans and protects your coil with Teflon. Helps coils resist dirt and grime. Extends coil service life in salt air environments and allows longer periods between cleaning

## Insulation Products

- Cork and Foam Insulation Tapes, Insulation sealing plugs and Nufoam (expanding polyurethane), products to meet all your insulation and sealing requirements

## Gas Leak Detectors

- Cal-Blue: Detects the smallest leaks due to its high viscosity formula. Non-corrosive to metals and offers freeze protection in -20 degree, 0 degree and 5 degree Fahrenheit

## Sprayers

- Pump sprayer for coil cleaners. Available in 1/2 gallon, 2 gallon and 3 gallon capacities. Made of translucent polyethylene.

- Available from Carrier Transicold Dealers Nationwide



# Antifreeze/Coolant



## Features and Benefits

- Protects equipment from extreme temperatures
- Available in concentrate or pre-diluted 50/50

### SHELLZONE® All Season Antifreeze

- Multipurpose, low-silicate antifreeze for automotive engine and heavy-duty diesel or gasoline truck engine cooling systems
- Provides exceptional rust and corrosion protection in cooling systems
- Protection from extreme temperatures (-34°F to 260°F)

### DEX-COOL® Extended Life Antifreeze

- Protects all cooling system metals, including hard-to-protect aluminum components in high operating temperatures
- 5-year/150,000 miles coolant service life
- No abrasive additives for improved water pump life

### ROTELLA™ ELC Extended Life Coolant/Antifreeze

- Recommended for use in the cooling systems of all heavy-duty diesel, gasoline and natural gas engines
  - Designed to go a minimum of 600,000 miles with only one extender addition
  - Improved component life with fewer maintenance and disposal costs
  - Caterpillar EC-1 approved Environmentally Friendly
- Available from US Carrier Transicold Dealers

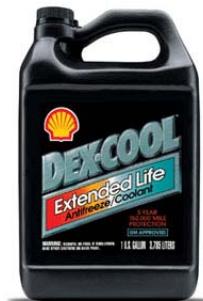

# Mobil Oil

Carrier  
TRANSICOLD  
PERFORMANCE  
PARTS

## Features and Benefits

- Mobil Delvac 1300 Super is the standard factory fill for all Carrier units produced at the Carrier Transicold Athens facility
  - Meets requirements of CI-4 and “CI-4 Plus” maintaining oil drain intervals regardless of fuel sulfur content
  - First Mobil CJ-4 oil introduced
  - Most advanced formulation of Mobil Delvac 1300 Super
  - Excellent oil consumption and deposit control for keep clean engine protection leading to extreme wear protection
- Enjoy superior unit performance, longer maintenance intervals and lower per unit operating costs with industry-leading Mobil Delvac 1 oil
  - Ultimate synthetic API CJ-4 Technology offering extended drain capabilities, potential fuel economy benefits and extreme temperature performance
- Competitively priced for incredible savings
- Contact your local Carrier Transicold Dealer for more information about Mobil engine oils and lubricants



### Available Products

**DELVAC 1**  
**DELVAC 1300 SUP 15W-40**  
**DELVAC XTREME SERVICE GREASE**  
**MOBILGREASE XHP 222**  
**MOBILITH SHC 007**  
**MOBILUBE HD PLUS 80W-90**  
**MOBILUBE HD PLUS 85W-140**  
**DELVAC SYN GEAR OIL 75W-90**  
**DELVAC SYN GEAR OIL 80W-140**  
**MOBIL 1 SYNTHETIC GEAR LUBE**  
**MOBIL 1 SYNTHETIC ATF**  
**MULTIPURPOSE ATF**  
**MOBILTRANS HD 50**  
**DELVAC SYN TRANS FLUID 50**  
**MOBIL 1 5W-30**  
**HUMBLE HYD AW-32**

Carrier  
TRANSICOLD  
PERFORMANCE  
PARTS

**Mobil**<sup>®</sup>

Carrier  
TRANSICOLD  
Turn to the Experts

\*Mobil<sup>®</sup> is a registered trademark of Exxon Mobil Corporation























Parts Where Used - Numerical Sequence

TK P/N	CTD P/N	DESCRIPTION	COMPRESSOR	ENGINES	TRAILER	TRUCK
44 2100	10 00072 02	SWITCH, TOGGLE				
44 2152	09 00138 00	ELEMENT				
44 2170	30 00171 28	DIODE ASSY, ISOLATION				
44 2193	30 00171 10	CABLE, ASSEMBLY				
44 2219	30 50001 01	BRUSH SET, ALTERNATOR				
44 2260	12 00136 00	GAUGE, OIL PRESSURE				
44 2286	30 00306 14	FAN				
44 2587	22 15272 00	HOLDER, FUSE				
44 2596	10 00171 09	CIRCUIT BREAKER 15 AMP				
44 2602	20 44 2802	PLUG SOCKET				
44 2756	22 01030 17	DIODE ASSY, RUN/SPEED SOLENOID				
44 2814	20 44 2814	GAUGE, WATER TEMP				
44 2823	10 01095 00	SOLENOID				
44 2847	34 50009 01	PLUNGER ASSY				
44 2853	10 00279 00	CONTACTOR				
44 2911	20 44 2911	SOLENOID				
44 2922	20 44 2922	GLOW PLUG				
44 3018	20 44 3018	SWITCH, ENGINE WATER SAFETY				
44 3155	20 44 3155	SWITCH, DEFROST				
44 3183	20 44 3183	SWITCH START PREHEAT				
44 3184	10 01153 00	SOCKET, RELAY				
44 3186	20 44 3186	RELAY, DEFROST				
44 3258	20 44 9302	GAUGE, AMMETER				
44 3280	10 01120	RECTIFIER				
44 3325	20 44 3325	ALTERNATOR ASSY 37 AMP				
44 3473	20 44 3473	GAUGE, HOUR METER				
44 3474	12 01039 08	AIR SWITCH				
44 3516	10 00171 09	CIRCUIT BREAKER 25 AMP				
44 3555	12 01039 08	AIR SWITCH				
44 3711	22 01467 00	BULB, WEDGE TYPE				
44 3781	10 01078 01	TRANSFORMER				
44 3842	20 44 3842	DIODE HARNESS				
44 3843	12 50021 00	SWITCH, PRESSURE LOW				
44 3930	20 44 3930	COIL, SOLENOID, 12V				
44 4139	30 00363 19	SLIP RING				
44 4238	10 00171 03	CIRCUIT BREAKER 20 AMP				
44 4258	20 44 4258	SWITCH, PRESSURE				
44 4435	54 00508 30	BRUSHES, GE MOTORS 104-343 & 344				
44 4546	25 321 13	CONDENSER				
44 4569	10 00171 09	CIRCUIT BREAKER 15 AMP				
44 4661	22 01131 03	RECEPTACLE				
44 4728	20 44 4728	GLOW PLUG, YANMAR HOSE TYPE				
44 4774	20 44 4774	SWITCH OIL SAFETY				
44 5013	20 44 5013	VOLTAGE REGULATOR				
44 5066	22 02430 00	TERMINAL, FEMALE 1/4 STR				
44 5175	14 50021 02	COIL, MODULATION VALVE				
44 5214	20 44 5214	SOCKET 12 CONTACT				
44 5227	20 44 5227	PLUG 12 CONTACT				
44 5234	20 44 5234	SENSOR, 3000 OHM				
44 5236	20 44 5236	SENSOR				
44 5262	10 01165 00	GAUGE, HOUR METER				
44 5293	10 00171 03	CIRCUIT BREAKER 20 AMP				





Parts Where Used - Numerical Sequence

TK P/N	CTD P/N	DESCRIPTION	COMPRESSOR	ENGINES	TRAILER	TRUCK
45 1003	20 45 1003RB	3K THERMOSTAT, REBUILT				
45 1065	20 45 1065RB	3K THERMOSTAT, REBUILT				
45 1071	20 45 1071RB	3K THERMOSTAT, REBUILT				
45 1083	20 45 1083RB	3K THERMOSTAT, REBUILT				
45 1084	20 45 1084RB	3K THERMOSTAT, REBUILT				
45 1085	20 45 1085RB	3K THERMOSTAT, REBUILT				
45 1086	20 45 1086RB	3K THERMOSTAT, REBUILT				
45 1087	20 45 1087RB	3K THERMOSTAT, REBUILT				
45 1135	20 45 1135RB	3K THERMOSTAT, REBUILT				
45 1227	20 45 1227	COIL, 24 V. BUS CLUTCH				
45 1251	20 45 1251	STARTER, YANMAR 235 & 353				
45 1263	20 45 1993	STARTER, ISUZU 2.2 DI				
45 1285	20 45 1285	STARTER, ISUZU C201				
45 1300	20 45 1300	BATTERY BOX, SS				
45 1312	20 45 1718	STARTER, YANMAR 366 & 388				
45 1375	20 45 1375RB	3K THERMOSTAT, REBUILT				
45 1389	20 45 1389	COIL, 24V CLUTCH				
45 1440	20 45 1440RB	MicroP IV CONTROLLER, REBUILT				
45 1441	20 45 1441RB	MicroP IV CONTROLLER, REBUILT				
45 1511	20 45 1511RB	MicroP IV CONTROLLER, REBUILT				
45 1512	20 45 1512RB	MicroP IV CONTROLLER, REBUILT				
45 1517	20 45 1517RB	MicroP IV CONTROLLER, REBUILT				
45 1520	20 45 1520RB	MicroP IV CONTROLLER, REBUILT				
45 1521	20 45 1521RB	MicroP IV CONTROLLER, REBUILT				
45 1524	20 45 1524RB	MicroP IV CONTROLLER, REBUILT				
45 1557	20 45 1557RB	MicroP IV CONTROLLER, REBUILT				
45 1558	20 45 1558RB	MicroP IV CONTROLLER, REBUILT				
45 1564	20 45 1564	THERMOSTAT, ELECTRONIC, 1 PIECE TYPE				
45 1565	20 45 1565	THERMOSTAT, ELECTRONIC, USES RELAY PACK				
45 1570	20 45 1570RB	MicroP IV CONTROLLER, REBUILT				
45 1596	20 45 1596RB	MicroP IV CONTROLLER, REBUILT				
45 1597	20 45 1597RB	MicroP IV CONTROLLER, REBUILT				
45 1600	20 45 1600RB	MicroP IV CONTROLLER, REBUILT				
45 1601	20 45 1601RB	MicroP IV CONTROLLER, REBUILT				
45 1671	20 45 1993	STARTER, ISUZU 2.2 DI				
45 1676	20 45 1676RB	MicroP IV RELAY BOARD, RAIL UNITS, REBUILT				
45 1688	20 45 1688	STARTER, 486 ENGINES				
45 1718	20 45 1718	STARTER				
45 1791	20 45 1791	HEATER, TK EVAPORATOR (CONTAINER)				
45 1841	20 45 1841RB	MicroP VI CONTROLLER, REBUILT				
45 1930	20 45 1930RB	MicroP VI CONTROLLER, REBUILT				
45 1993	20 45 1993	STARTER, ISUZU 2.2 DI				
45 1998	20 45 1998	COIL, 24V CLUTCH				
55 308	40 00102 03	ELBOW, 1/8 MALE PIPE X 1/4 MALE FLARE				
55 370	20 55 370	WASHER, SS COMP SIGHT GLASS				
55 381	20 55 381	O-RING, COPPER TK COMP				
55 386	20 55 386	O-RING, COPPER TK COMP				
55 466	40 00102 03	ELBOW, 1/4 MALE PIPE X 1/4 MALE FLARE				
55 644	40 00102 12	ELBOW, 3/8 MALE PIPE X 1/2 MALE FLARE				
55 664	20 55 664	NUT				
55 692	66U1 6821 2	WASHER				
55 895	20 55 895	O-RING, STEEL TK COMP 5/16"				











Parts Where Used - Numerical Sequence

TK PIN	CTD PIN	DESCRIPTION	COMPRESSOR										ENGINES								TRAILER						TRUCK						
			X214	426	X426	X430	X430 LS	2.2 D.I.	C-201	486	395	388	374	366	353	249	235	SNWD	SB-1	SB-II	SB-III	SB SERIES	SUPER	SENTRY	SMX	TD	JD	KD	RD	MD	TS		
78 626	20 78 626	BELT, LND 30 & 60 FAN & ALT																															
78 628	20 78 628	BELT, LND WITH ELECTRIC CLUTCH																															
78 629	20 78 629	BELT																															
78 632	20 78 632	BELT SB 11																															
78 656	20 78 656	BELT																															
78 666	20 78 666	BELT																															
78 667	20 78 667	BELT																															
78 668	20 78 668	BELT																															
78 669	20 78 669	BELT																															
78 679	20 78 679	BELT																															
78 684	20 78 684	BELT																															
78 689	20 78 689	BELT																															
78 697	20 78 697	BELT																															
78 698	20 78 698	BELT																															
78 700	20 78 700	BELT																															
78 721	20 78 721	BELT																															
78 723	20 78 723	BELT, SET OF 2																															
78 731	20 78 731	BELT																															
78 747	20 78 747	BELT																															
78 751	20 78 751	BELT																															
78 757	20 78 757	BELT																															
78 765	20 78 765	BELT																															
78 766	20 78 766	BELT																															
78 767	20 78 767	BELT																															
78 773	20 78 773	BELT																															
78 784	20 78 784	BELT																															
78 785	20 78 785	BELT																															
78 787	20 78 787	BELT																															
78 800	20 78 800	BELT																															
78 804	20 78 804	BELT																															
78 805	20 78 805	BELT																															
78 809	20 78 809	BELT																															
78 826	20 78 826	BELT																															
78 827	20 78 827	BELT																															
78 835	20 78 835	BELT																															
78 837	20 78 837	BELT																															
78 841	20 78 841	BELT																															
78 842	20 78 842	BELT																															
78 843	20 78 843	BELT																															
78 844	20 78 844	BELT																															
78 845	20 78 845	BELT																															
78 890	20 78 890	BELT																															
78 896	20 78 896	BELT																															
78 898	20 78 898	BELT																															
78 899	20 78 899	BELT																															
78 900	20 78 900	BELT																															
78 905	20 78 905	BELT																															
78 928	20 78 928	BELT																															
78 929	20 78 929	BELT																															
78 936	20 78 936	BELT																															
78 941	20 78 941	BELT																															
78 977	20 78 977	BELT																															

NEW







Parts Where Used - Numerical Sequence

TK P/N	CTD P/N	DESCRIPTION	COMPRESSOR	ENGINES	TRAILER	TRUCK
204 458	07 00206 01	FLASH TUBE, XENON				
204 476	46 50002 00	GREASE, EXXON N-2 (14 ounce tube)				
204 487	07 00238	REFRIGERATION WRENCH				
204 494	07 00177 01	ASPIRATOR				
204 526	07 00314 00	KIT, GAUGE SET "CFC"				
204 542	07 00179 01	COMPRESSION TESTER				
204 544	07 00179 07	CHART, COMP (150 - 850 PSI)				
204 548	07 00255 11	ELEMENT, FOR 07-00255-10 CFC LEAK DETECTORS				
204 561	07 00237 06	GAUGE, PRESSURE FOR 07-00314-00 CFC				
204 562	07 00237 05	GAUGE, COMPOUND FOR 07-00314-00 CFC				
204 622	07 00277 00	KIT, STATIC DISSIPATE				
204 622	07 00304 00	STRAP, GROUNDING				
204 623	07 00254 00	PIN, EXTRACTOR AMP CONNECTOR				
204 624	07 00330 00	CRIMPER, ML-2 & ML-2I CONNECTORS				
204 635	07 00298 00	INSERTER (EPROM)				
204 636	07 00297 00	EXTRACTOR (EPROM)				
204 677	AC101 708	HOSE CUTTER TOOL				
204 678	AC101 711	BLADE, HOSE CUTTER TOOL AC101-707				
204 680	07 00240 01	WRENCH, SPANNER FOR CLUTCH ARMATURE				
204 681	AC101 707	CLUTCH TOOL, VARI SPEED COMPRESSOR DKS-26				
204 699	07 00176 11	VACUUM PUMP, 110-115/220-240V 50/60 HZ				
204 713	07 00176 11	VACUUM PUMP, 110-115/220-240V 50/60 HZ				
204 740	07 00315 00	AUTO CHARGING METER				
204 758	07 00294	MANIFOLD GAUGE SET FOR R134a				
204 783	07 00237 04	HANDWHEEL PKG				
204 784	07 00294 01	GAUGE, COMPOUND FOR 07-00294-00 R-134a				
204 785	07 00294 02	GAUGE, PRESSURE FOR 07-00294-00 R-134a				
204 791	07 00307 05	COUPLER QUICK CONN, HIGH SIDE R-134A				
204 792	07 00307 04	COUPLER QUICK CONN, LOW SIDE R-134A				
204 793	07 00301 00	ADAPTER, 1/4" FEMALE FLARE X 1/2" ACME				
204 825	07 00294 05	GAUGE SET (METRIC)				
204 845	07 00323 00	NON CONTACT THERMOMETER				
204 846	07 00324 00	NON CONTACT THERMOMETER				
204 850	07 00307 01	HOSE, (YELLOW) 1/2 ACME X 1/2 ACME BARRIER 72"				
204 851	07 00307 02	HOSE, GAUGE (RED) 1/2 ACME X 14 MM BARRIER 72"				
204 852	07 00307 03	HOSE, GAUGE (BLUE) 1/2 ACME X 14 MM BARRIER 72"				
301 123	14 50037 00	FILTER DRIER T TYPE				
301 124	14 50037 00	FILTER DRIER T TYPE				
301 134	38 00515 00	FILTER, DRIVERS HEATER				
302 153	20 302 153	CRANKSHAFT, GB COMPRESSOR				
303 114	20 303 114	GASKET, HEAD				
303 116	20 303 116	GASKET, DISTRIBUTOR COVER				
303 182	20 303 182	GASKET, OIL PUMP COVER				
303 201	17 10812 00	GASKET, PLASTIC SERVICE VALVE CAP				
303 253	20 33 408	O-RING				
303 266	20 33 726	O-RING				
304 126	10 00302 00	RECEPTICAL (BASE RELAY)				
304 179	10 00303 01	CIRCUIT BREAKER 15 AMP				
304 185	10 00303 03	CIRCUIT BREAKER 50 AMP				
304 187	10 00303 02	CIRCUIT BREAKER 35 AMP				
304 272	20 304 272	COIL, CLUTCH 24 VOLT PITTS				
304 302	10 00300 00	CONTACTOR, N.O.				

NEW

Parts Where Used - Numerical Sequence

TK P/N	CTD P/N	DESCRIPTION	COMPRESSOR	ENGINES	TRAILER	TRUCK
304 327	12 00272.01	CONTROLLER, REHEAT				
304 328	12 00272.00	CONTROLLER, CYCLING CLUTCH				
304 357	12 00272.02	CONTROLLER, HEAT ONLY				
304 570	22 01585.00	RECEPTICAL, 2 WAY				
304 589	10 00301.00	RELAY				
304 596	10 00286.03	RELAY				
304 636	22 01593.00	RESISTOR, DRIVERS HEATER				
304 648	22 01583.00	RESISTOR, SHORT, EVAP 240 WATTS				
304 649	22 01584.00	RESISTOR, LONG, COND 420 WATTS				
305 191	44 01140.00	CLAMP, HOSE, DRIVERS HEATER				
305 492	20 305 492	SCREW, GB CRANK				
305 549	40 00107.01	TEE, 1/8" FPT X FPT X FPT				
306 115	17 21002.01	VALVE STEM CAP				
306 121	17 10812	CAP, SERVICE VALVE				
306 194	68BH 401 104	COIL, DRIVERS HEATER				
306 217	14 50037.00	FILTER DRIER, T TYPE				
306 255	20 306 255	SIGHT GLASS				
306 267	20 306 615	TXV POWER HEAD				
306 578	EP23SC090	VALVE, OIL DRAIN 90				
306 599	40 00117.01	DRAIN COCK				
306 615	20 306 615	TXV VALVE ASSEMBLY				
306 635	40 00480.00	VALVE, HOT WATER SHUT OFF				
306 640	14 01109.02	VALVE, PRESSURE RELIEF				
306 661	14 01106.00	VALVE, SHUT OFF				
307 116	20 307 116	BEARING, 4GB SEAL END MAIN				
307 117	20 307 117	BEARING, 4GB PUMP END MAIN				
307 128	20 307 128	BEARING, CLUTCH 50MM GB, PITTS				
307 142	04 00034.00	BUSHING, SLIT TAPER				
307 172	20 307 172	CLUTCH 3 GROOVE 3V RG 50MM				
307 173	20 307 173	CLUTCH 2 GROOVE 5V RG 50MM				
309 615	EK02JA210	FUSIBLE PLUG 210 F				
810 1257	20 10 1257RM	2.2DI, REMAN ENGINE				
810 2647	20 X430LS COMP	COMPRESSOR, REMAN, X430 LARGE SHAFT CRANK	X			
844 3325	20 44 3325RM	ALTERNATOR, REMANUFACTURED				
844 6257	20 44 6257RM	ALTERNATOR, REMANUFACTURED				
844 6266	20 44 6266RM	ALTERNATOR, REMANUFACTURED				
844 9571	20 44 9571RM	ALTERNATOR, REMANUFACTURED				
844 9572	20 44 9572RM	ALTERNATOR, REMANUFACTURED				
845 1251	20 45 1251RM	STARTER, REMANUFACTURED				
845 1263	20 45 1263RM	STARTER, REMANUFACTURED				
845 1285	20 45 1285RM	STARTER, REMANUFACTURED				
845 1312	20 45 1312RM	STARTER, REMANUFACTURED				
845 1724	20 45 1724RM	STARTER, REMANUFACTURED				
N/A	20-20-X214-WC	COMP. REBUILD KIT, X214 W/CRANK & RODS	X			
N/A	20-20-X214-WOC	COMP. REBUILD KIT, X214 W/O CRANK & RODS	X			
N/A	20 10 2.2DI 025	KIT, 2.2DI OVERHAUL w/ 0.25 PISTONS, STD. BRGS.		X		
N/A	20 10 2.2DI 050	KIT, 2.2DI OVERHAUL w/ 0.50 PISTONS, STD. BRGS.		X		
N/A	20 10 2.2DI STD	KIT, 2.2DI OVERHAUL w/STD. PISTONS, STD. BRGS.		X		
N/A	20 20 426F WC	COMP. REBUILD KIT, 426F W/CRANK & RODS				
NA	20 20 426F WOC	COMP. REBUILD KIT, 426F W/O CRANK & RODS	X			
NA	20 20 X426 WC	COMP. REBUILD KIT, X426 W/CRANK & RODS	X			
NA	20 20 X426 WOC	COMP. REBUILD KIT, X426 W/O CRANK & RODS	X			





# Alternators/Regulators



**New 23 Amp Alternator**  
TK P/N 41-2194  
Carrier P/N 30-50345-00



**New 37 Amp Alternator**  
TK P/N 41-2195  
Carrier P/N 30-50341-00



**New 65 Amp Alternator**  
TK P/N 41-2197  
Carrier P/N 30-50342-00

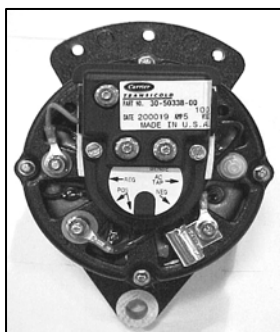

**New 37 Amp Alternator**  
TK P/N 41-2198  
Carrier P/N 30-50337-00

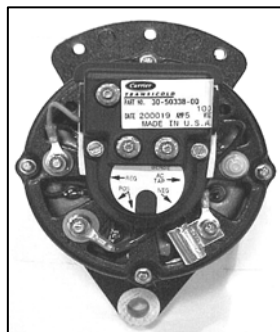

**New 65 Amp Alternator**  
TK P/N 41-2200  
Carrier P/N 30-50336-00

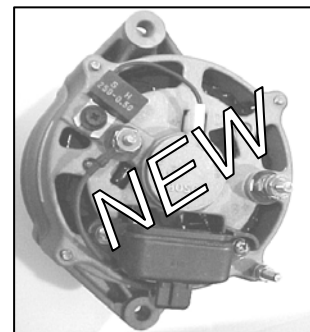

**New 37 Amp Alternator**  
TK P/N 41-5458  
Carrier P/N 20-41-5458

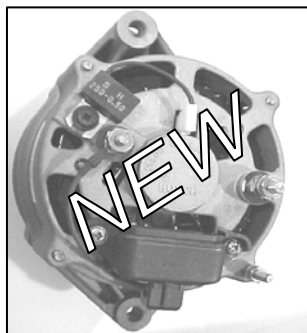

**New 65 Amp Alternator**  
TK P/N 41-5457  
Carrier P/N 20-41-5457

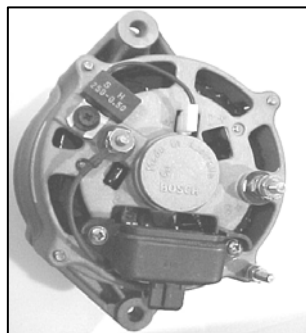

**New 90 Amp Alternator**  
Carrier P/N 30-50340-00

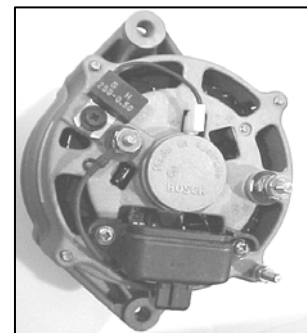

**New 120 Amp Alternator**  
TK P/N 41-5456  
Carrier P/N 20-41-5456

Our New And Remanufactured Alternators Come With  
An Extended Warranty. Contact Your Local  
Carrier Transicold Dealer For Details.

# Alternators/Regulators

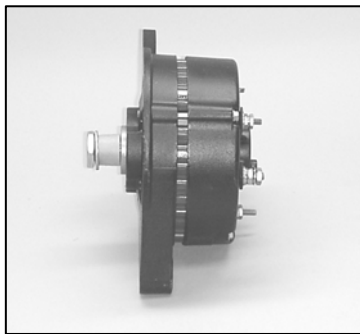

**Reman 51 Amp Alternator**  
TK P/N 844-6257  
Carrier P/N 20-44-6257RM

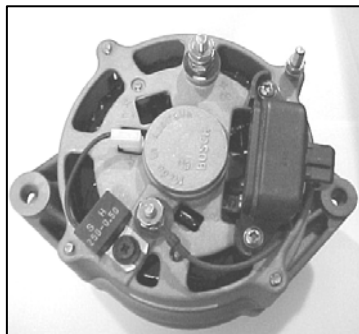

**Reman 37Amp Alternator**  
TK P/N 844-9571  
Carrier P/N 20-44-9571RM

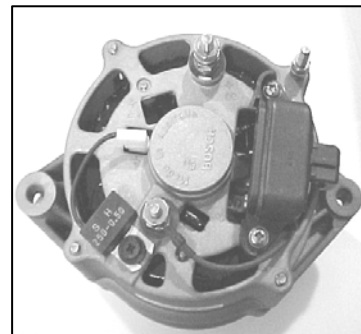

**Reman 65 Amp Alternator**  
TK P/N 844-9572  
Carrier P/N 20-44-9572RM



**Regulator**  
TK P/N 41-1740  
Carrier P/N 30-50338-00

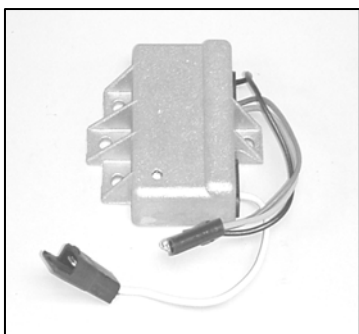

**Regulator**  
TK P/N 44-2039  
Carrier P/N 10-00265-01



**Regulator**  
TK P/N 44-5013  
Carrier P/N 20-44-5013

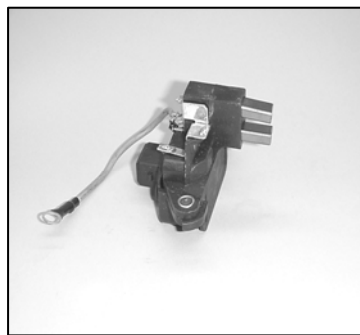

**Regulator**  
TK P/N 44-9143  
Carrier P/N 20-44-9143



**Harness, Bosch Alt.**  
TK P/N 44-9041  
Carrier P/N 20-44-9041

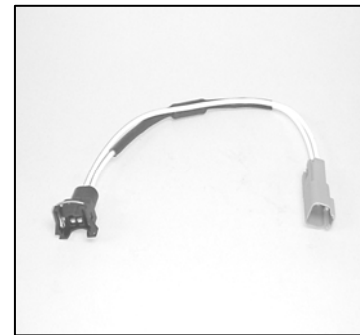

**Harness, Bosch Alt.**  
TK P/N 44-9336  
Carrier P/N 20-44-9336

# Alternators/Regulators

DESCRIPTION	TK P/N	CTD P/N
Alternator assy, 37 amp Prestolite	41 2195	30 50341 00
Alternator assy, 65 amp Prestolite	41 2197	30 50342 00
Alternator assy, 37 amp Prestolite	41 2198	30 50337 00
Alternator assy, 65 amp Prestolite	41 2200	30 50336 00
Alternator assy, 37 amp	44 3325	20 44 3325
Alternator assy, 51 amp	44 6257	20 44 6257
Alternator assy, remanufactured	844 3325	20 44 3325RM
Alternator assy, remanufactured	844 6257	20 44 6257RM
Alternator assy, remanufactured	844 6266	20 44 6266RM
Alternator assy, remanufactured	844 9571	20 44 9571RM
Alternator assy, remanufactured	844 9572	20 44 9572RM
Bearing, sealed, alt	77 671	30 00171 20
Bearing, sealed, alt	77 672	30 00171 17
Brush set, alternator	44 2219	30 50001 01
Brush set, alternator	44 7320	30 00363 25
Cable, assembly	44 2193	30 00171 10
Diode assy, isolation	44 2170	30 00171 28
Diode, field, atl	44 7255	30 00363 21
Harness, Bosch alternator	44 9041	20 44 9041
Harness, Bosch alternator	44 9336	20 44 9336
Housing, front, alt	44 7315	30 00363 16
Key, woodruff, alt	55 1600	30 00171 31
Nut, mtg fan, alt	55 2042	30 00171 13
Regulator, voltage	41 1740	30 50338 00
Regulator, voltage	44 2039	10 00265 01
Regulator, voltage	44 5013	20 44 5013
Regulator, voltage, Bosch	44 9143	20 44 9143
Spacer, fan alt	44 7323	30 00363 25
Stator, alt	44 7318	30 00363 20

# Belts

## SB I

### TK P/N

### CTD P/N

Fan (X426 Comp)	78 470	20 78 470
Alternator	78 471	20 78 471
Fan (X430 Comp)	78 553	20 78 553

## SB II

Alternator & Water Pump	78 471	20 78 471
Alternator	78 751	20 78 751
Fan	78 603	20 78 603
Engine to Idler	78 604	20 78 604
2.2DI & 2.2DI SE Engines	78 667	20 78 667
Compressor Drive	78 784	20 78 784
Alternator to Water Pump	78 929	20 78 929

## SB III

Fan	78 603	20 78 603
Engine to Idler	78 629	20 78 629
Fan	78 844	20 78 844
Alternator	78 845	20 78 845
Alternator to Water Pump	78 929	20 78 929
Water Pump to Alternator	78 1341	20 78 1341

## SB (100/110/190/200/210/300/400)

Fan (SB 100/190/200/300)	78 603	20 78 603
Engine to Idler (SB 100/190/200/300)	78 629	20 78 629
Fan	78 844	20 78 844
Alternator (SB 100/190)	78 929	20 78 929
Water Pump to Alternator (SB 200/300)	78 1341	20 78 1341
Water Pump to Crank Pulley (30's & 50's)	78 1340	20 78 1340

## SUPER II

Fan	78 835	20 78 835
Alternator	78 471	20 78 471
Alternator	78 751	20 78 751
Fan	78 1000	20 78 1000
Water Pump to Alternator	78 1341	20 78 1341
Water Pump to Crank Pulley (30's & 50's)	78 1340	20 78 1340

## SENTRY

Fan (X426 Comp)	78 556	20 78 556
Fan (X430 Comp)	78 666	20 78 666
Engine to Idler	78 757	20 78 757
Alternator	78 471	20 78 471
Alternator	78 751	20 78 751

## Belts

### SNWD & NWD (50 Series)

	TK P/N	CTD P/N
Fan	78 287	20 78 287
Alternator	78 362	20 78 362
Clutch Drive (Set of Two)	78 368	20 78 368

### XNWD

	TK P/N	CTD P/N
Fan	78 428	20 78 428
Alternator	78 429	20 78 429

### RMU

Drive Belt (Set of Two)	78 466	20 78 466
-------------------------	--------	-----------

### XMT

Evap. Fan Drive	78 339	20 78 339
Compressor to Engine	78 341	50 01121 01
Motor to Compressor	78 340	20 78 340
Alternator	78 467	20 78 467

### XMD

Engine to Compressor	78 432	20 78 432
Engine to Compressor (R502)	78 486	20 78 486
Fan Drive	78 436	20 78 436

### JD-I & JD-II

Water Pump (JD-I & JDII)	78 679	20 78 679
Engine to Motor to Alternator (JD-II, Before 7/96)	78 905	20 78 905
Water Pump	78 1012	20 78 1012
Engine to Motor to Alternator (JD-II, 7/96 and After)	78 1048	20 78 1048

### MD-I & MD-I SSVI

Water Pump 2 Pulley	78 513	20 78 513
Engine to Compressor	78 432	20 78 432
Engine	78 436	20 78 436
Engine to Compressor (SSVI)	78 591	20 78 591
Engine (SSVI)	78 592	20 78 592

### MD-II & KD-II (30's & 50's)

Engine to Compressor (Use with 77-2431 Idler Pulley)	78 977	20 78 977
Engine to Compressor (KD-II Max w/3.74 Eng., R134a)	78 841	20 78 841
Motor/Jackshaft to Compressor (3/88 - 12/88)	78 585	20 78 585
Motor/Jackshaft to Compressor (Before 3/88)	78 689	20 78 689
Motor/Jackshaft to Compressor (After 12/88)	78 936	20 78 936
Compressor to Evaporator Fan	78 684	20 78 684
Alternator to Evaporator Fan	78 700	20 78 700
Water Pump (3.74 Engine)	78 1012	20 78 1012
Engine to Compressor (Use with 77-2407 Idler Pulley)	78 1083	20 78 1083

# Belts

## RD-I

	TK P/N	CTD P/N
Motor to Compressor (R12)	78 436	20 78 436
Motor to Compressor (R502)	78 898	20 78 898
Engine to Compressor (R12)	78 495	20 78 495
Engine to Compressor (R502)	78 500	20 78 500
Fan Drive	78 494	20 78 494

## RD-II & RD-II MAX

Water Pump	78 767	20 78 767
Evap Fan to Compressor	78 800	20 78 800
Engine to Compressor to Idler	78 900	20 78 900
Alternator to Evaporator Fan	78 766	20 78 766
Jackshaft to Compressor	78 898	20 78 898
Water Pump (3.95 Engine)	78 1026	20 78 1026

## TD-II (30's & 50's)

Compressor to Evaporator Fan	78 698	20 78 698
Evaporator Fan	78 766	20 78 766
Water Pump	78 767	20 78 767
Compressor to Evaporator Fan (R12/R134a)	78 800	20 78 800
Engine to Idler to Compressor	78 896	20 78 896
Motor/Jackshaft to Compressor (R502)	78 898	20 78 898
Motor/Jackshaft to Compressor (R12/R134a)	78 899	20 78 899
Water Pump (3.95 Engine)	78 1026	20 78 1026

## TS Truck Units

Water Pump (3.74 Engine)	78 1012	20 78 1012
Engine / Motor (TS 200/300/500)	78 1062	20 78 1062
Motor / Compressor (TS 500)	78 1067	20 78 1067
Poly V (TS 200/300)	78 1129	20 78 1129
Motor / Compressor (TS 600)	78 1134	20 78 1134
Engine / Motor (TS 600)	78 1137	20 78 1137
Water Pump (3.95 Engine)	78 1026	20 78 1026
Motor / Compressor (TS 600)	78 1263	20 78 1263

## LND (30's & 50's)

Idler to Fan Shaft (30's)	78 668	20 78 668
Idler to Fan Shaft (50's)	78 671	20 78 671
Fan & Alternator (30's & 50's)	78 626	20 78 626
Engine to Idler (30's & 50's)	78 669	20 78 669
Water Pump	78 513	20 78 513

# Clutches & Drive Components

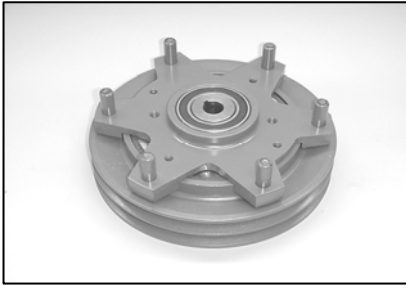

**Centrifugal Clutch**  
 SB, Sentry, Super (50's)  
 TK P/N 107-234  
 Carrier P/N 20-107-234



**Centrifugal Clutch**  
 MD, KD, RD, TD, TS Units  
 TK P/N 107-291  
 Carrier P/N 20-107-291

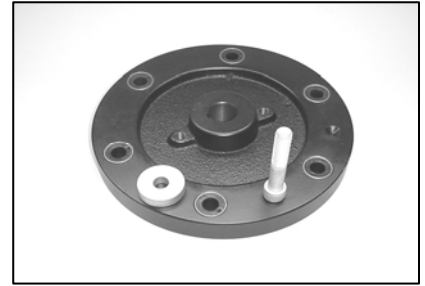

**Coupling**  
**(2.2DI & Large Shaft X430)**  
 TK P/N 77-2509  
 Carrier P/N 20-77-2509

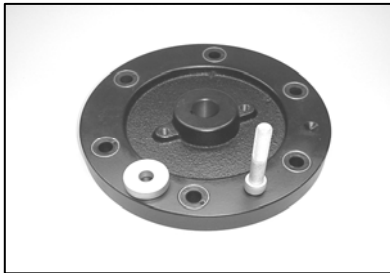

**Coupling, 6 Pin**  
**(2.2DI & Std. Shaft X430)**  
 TK P/N 77-2504  
 Carrier P/N 20-77-2504



**Coupling, 8 Pin**  
**(Includes Bolt & Washer)**  
 TK P/N 77-2506  
 Carrier P/N 20-77-2506

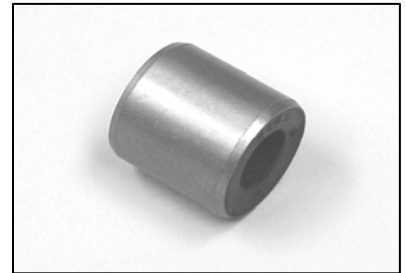

**Bushing, coupler**  
 TK P/N 77-2748  
 Carrier P/N 20-77-2748



**Bolt, M12 x 70mm long**  
 TK P/N 55-9031  
 Carrier P/N 20-55-9031



**Bolt, M12 x 80mm long**  
 TK P/N 55-9092  
 Carrier P/N 20-55-9092

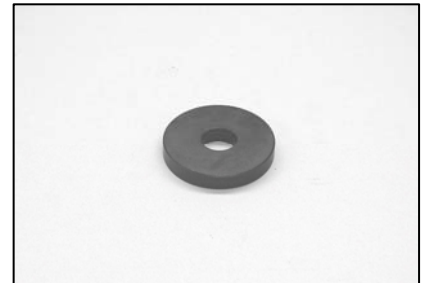

**Spacer, Coupler**  
 TK P/N 77-2505  
 Carrier P/N 20-77-2505



**Pulley, Idler**  
 TK P/N 77-2003  
 Carrier P/N 20-77-2003



**Pulley, Idler**  
 TK P/N 77-2004  
 Carrier P/N 20-77-2004



**Shaft, Idler Pulley**  
 TK P/N 77-2613  
 Carrier P/N 20-77-2613



# Compressors & Components

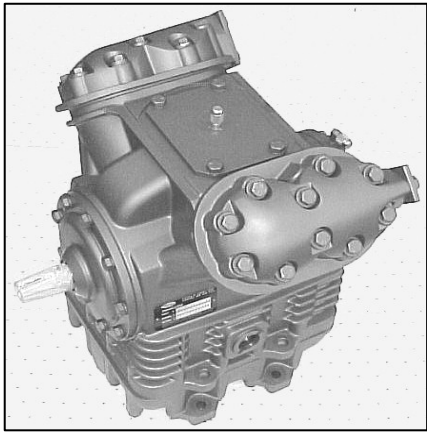

## Replacement Compressors

X430 Small Shaft - P/N 20-X430-COMP (CFC refrigerants only)

X430 Large Shaft - P/N 20-X430LS-COMP

X426 Compressor - P/N 20-X426-COMP

**These compressors are not just repaired, they are totally rebuilt. New parts include:**

Pistons, Connecting rods, Sleeves, Valve plates, Discharge valves, Crankshaft, Main bearings, Rod bearings, Shaft seal, Oil pump, Gaskets & O-rings.

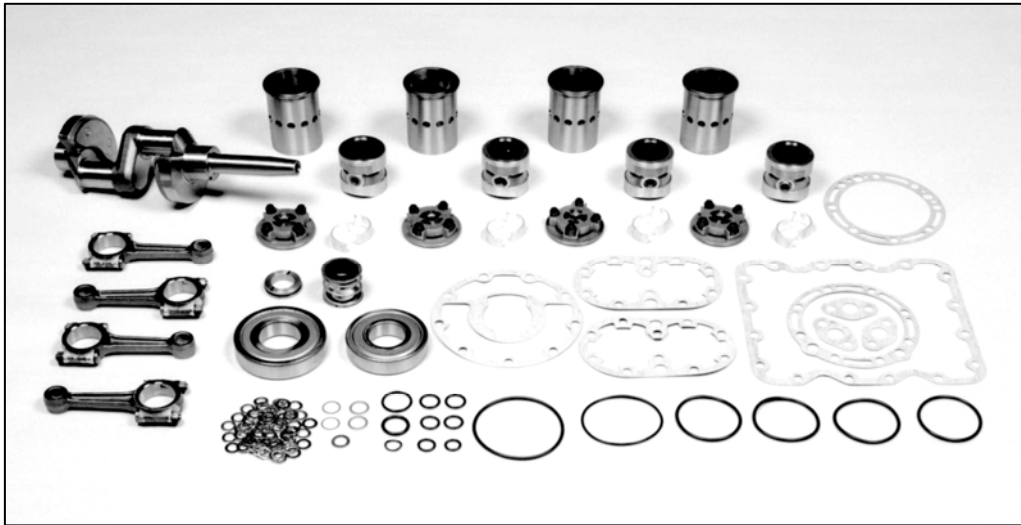

## COMPRESSOR REBUILD KITS

Large Shaft X430 - Use these kits when you are starting with a large shaft compressor.

P/N 20-20-X430LS-WC (with crank&rods)

P/N 20-20-X430LS-WOC (without crank&rods)

Small Shaft X430 (CFC Refrigerants Only)

P/N 20-20-X430-WC (with crank&rods)

P/N 20-20-X430-WOC (without crank&rods)

X426 Compressor

P/N 20-20-X426-WC (with crank&rods)

P/N 20-20-X426-WOC (without crank&rods)

426F Compressor

P/N 20-20-426F-WC (with crank&rods)

P/N 20-20-426F-WOC (without crank&rods)

X214 Compressor

P/N 20-20-X214-WC (with crank&rods)

P/N 20-20-X214-WOC (without crank&rods)

Kits for rebuilding small shaft compressors being used in **R404a** and **R134a** systems. They include the 20-77-2306 sealed bearing and 20-22-1100 metal bellows shaft seal

X430 Compressors

P/N 20-20-X430HP-WC (with crank & rods)

P/N 20-20-X430HP-WOC (without crank & rods)

X426 Compressors

P/N 20-20-X426HP-WC (with crank & rods)

P/N 20-20-X426HP-WOC (without crank & rods)

# Compressors & Components



## Included in Kit

- Crankshaft
- Shaft Seal
- Pistons
- Valve Plates
- Sleeves
- Cover Plate
- 20-77-2509 Coupler
- Main Bearings
- Rod Bearings
- Gasket Set
- Suction Screen

## X430 Large Shaft Conversion Kit

TK P/N 20-169

Carrier P/N 20-20-169

**This kit includes everything you need to convert an existing small shaft compressor into a large shaft compressor.**

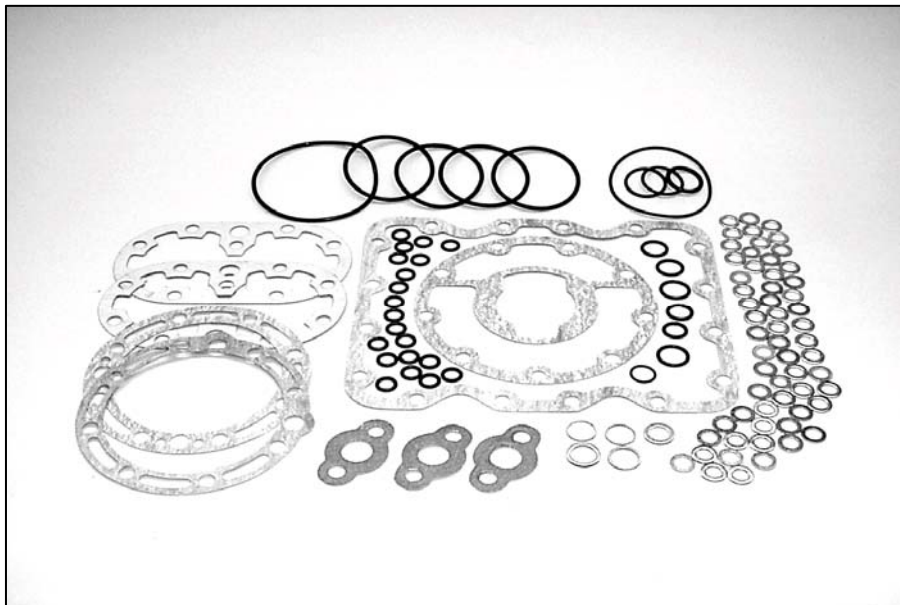

## Gasket Kits

**X430 & X426 Compressors**

Carrier P/N 20-30-243

**X214 Compressor**

Carrier P/N 20-30-247

# Compressors & Components

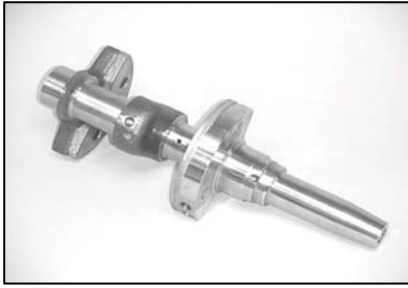

**Crankshaft (X430, Large)**  
TK P/N 22-1027  
Carrier P/N 20-22-1027



**Crankshaft (X430, Small)**  
TK P/N 22-655  
Carrier P/N 20-22-655



**Crankshaft (X426)**  
TK P/N 22-586  
Carrier P/N 22-586



**Crankshaft (426)**  
TK P/N 22-439  
Carrier P/N 20-22-439



**Crankshaft (X214)**  
TK P/N 22-804  
Carrier P/N 20-22-804



**Crankshaft (214 & D214)**  
TK P/N 22-373  
Carrier P/N 20-22-373



**Piston (X430)**  
TK P/N 22-850  
Carrier P/N 20-22-850



**Piston (426, X426, 214)**  
TK P/N 22-849  
Carrier P/N 20-22-849



**Connecting Rod**  
TK P/N 22-639  
Carrier P/N 20-22-639



**Sleeve (X430)**  
TK P/N 22-656  
Carrier P/N 20-22-656



**Sleeve (X426, 426, 214)**  
TK P/N 22-297  
Carrier P/N 20-22-297



**Sleeve (214D, X214D)**  
TK P/N 22-608  
Carrier P/N 20-22-608

# Compressors & Components

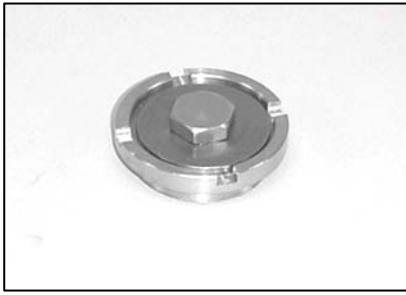

**Check Valve**  
TK P/N 22-787  
Carrier P/N 20-22-787

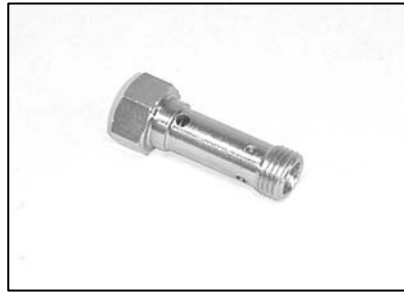

**Pressure Regulator**  
TK P/N 22-784  
Carrier P/N 20-22-784



**Check Valve**  
TK P/N 22-568  
Carrier P/N 20-22-568



**Check Valve**  
TK P/N 22-653  
Carrier P/N 20-22-653



**Oil Pump (X430 & X426)**  
TK P/N 22-1160  
Carrier P/N 20-22-1160



**Valve Plate**  
TK P/N 22-990  
Carrier P/N 20-22-990



**Bearing (Sealed X430)**  
TK P/N 77-2306  
Carrier P/N 20-77-2306



**Bearing (Crankshaft 214)**  
TK P/N 22-220  
Carrier P/N 20-22-220



**Bearing (Drive End)**  
TK P/N 77-167  
Carrier P/N 20-77-167



**Bearing (Pump End)**  
TK P/N 77-169  
Carrier P/N 20-77-169



**Bearings (Connecting Rod)**  
TK P/N 22-1003  
Carrier P/N 20-22-1003



**Shaft Seal (Metal Bellows)**  
TK P/N 22-1100  
Carrier P/N 20-22-1100

# Compressors & Components



**Shaft Seal (Large Shaft)**  
TK P/N 22-1101  
Carrier P/N 20-22-1101



**Shaft Seal**  
TK P/N 22-778  
Carrier P/N 20-22-778



**Shaft Seal (214 Comp.)**  
TK P/N 22-777  
Carrier P/N 20-22-777



**Shaft Seal (X214 Comp.)**  
TK P/N 22-899  
Carrier P/N 20-22-899

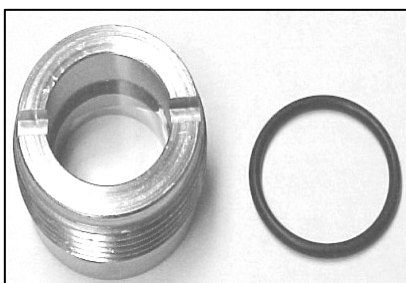

**Sight Glass**  
TK P/N 22-350  
Carrier P/N 20-22-350



**Suction Screen**  
TK P/N 22-306  
Carrier P/N 20-22-306



**Wrench, Sight Glass**  
TK P/N 204-244  
Carrier P/N 20-204-244



**Head, w/o Tapped Hole**  
TK P/N 22-789  
Carrier P/N 20-22-789



**Oil Pickup**  
TK P/N 22-611  
Carrier P/N 20-22-611

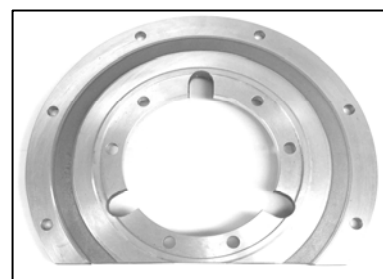

**Flange, compressor**  
TK P/N 22-723  
Carrier P/N 20-22-723



**Seal, Oil**  
TK P/N 33-2120  
Carrier P/N 20-33-2120

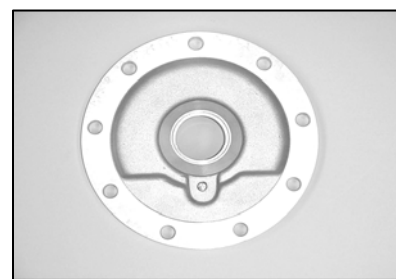

**Cover, large shaft**  
TK P/N 22-1028  
Carrier P/N 20-22-1028

## Doors & Accessories

DESCRIPTION	TK P/N	CTD P/N
BEARING DAMPER	99 6565	20 99 6565
BUSHING, DAMPER DOOR	99 2327	20 99 2327
DOOR, TOP, FIBERGLASS	98 3032	20 98 3032
DOOR LATCH, PLASTIC CURVED END	99 6599	99 6599 P10
DOOR LATCH, PLASTIC FLAT END	99 6900	99 6900 P10
DOOR, ROAD SIDE, ALUMINUM, PRE-PAINTED TK WHITE	98 4489	20 98 4489
DOOR, CURB SIDE, ALUMINUM, PRE-PAINTED TK WHITE	98 3030	20 98 3030
DOOR, ROAD SIDE, ALUMINUM, PRE-PAINTED TK WHITE	98 3031	20 98 3031
EVAP PANEL	98 753	20 98 753
HINGE	99 5264	20 99 5264
HINGE	99 5265	20 99 5265
HINGE, DOOR (SBII SBIII)	99 8021	20 99 8021
HINGE, DOOR (SBII SBIII)	99 8022	20 99 8022
HINGE, DOOR LEFT	99 2127	20 99 2127
HINGE, FRAME RIGHT	99 2128	20 99 2128
HINGE, FEMALE SBII	99 8029	20 99 8029
HINGE, MALE LH SBII	99 8104	20 99 8104
HINGE, MALE RH SBII	99 8304	20 99 8304
LATCH, DOOR	91 9621	20 91 9621
LATCH, DOOR	99 1175	20 99 1175 P10
LATCH, DOOR	99 1428	20 99 1428 P10
PANEL, CURBSIDE, ALUMINUM, PRE-PAINTED TK WHITE	98 2748	20 98 2748
SNWD GRILL, STAINLESS STEEL	98 2893	20 98 2893
STRIKE PLATE, DOOR	99 8103	20 99 8103
TOP CAP, FIBERGLASS, SBII	98 2747	20 98 2747



# Electrical

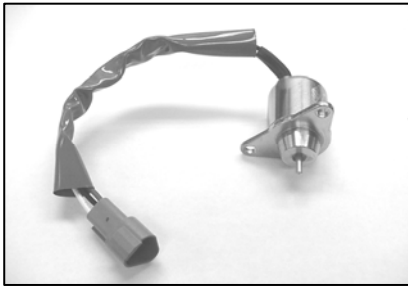

**Solenoid**  
TK P/N 41-4306  
Carrier P/N 20-41-4306



**Solenoid**  
TK P/N 44-9181  
Carrier P/N 20-44-9181

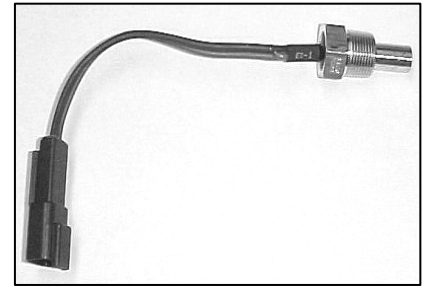

**Sensor (Water Temp)**  
TK P/N 41-2330  
Carrier P/N 20-41-2330



**Sensor (Graded)**  
TK P/N 40-871  
Carrier P/N 20-40-871



**Sensor (Un-Graded)**  
TK P/N 41-40-872  
Carrier P/N 20-40-872



**Switch (Water Temp)**  
TK P/N 44-3018  
Carrier P/N 20-44-3018

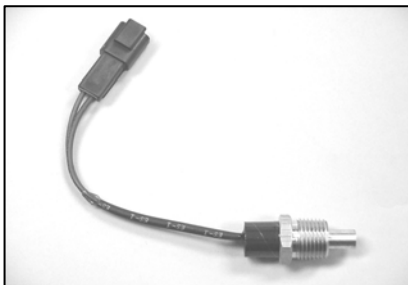

**Switch, Engine Temp.**  
TK P/N 41-740  
Carrier P/N 20-41-740

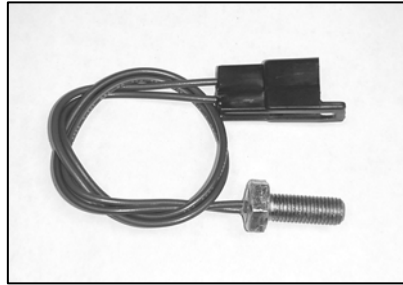

**Bolt Thermistor**  
TK P/N 44-6019  
Carrier P/N 20-44-6019

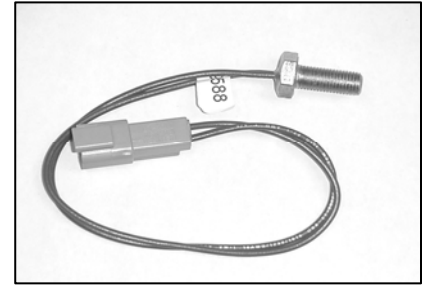

**Bolt Thermistor**  
TK P/N 44-9588  
Carrier P/N 20-44-9588

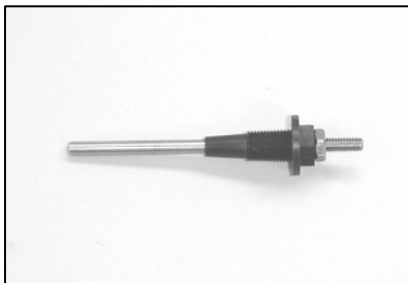

**Sensor, Water Level**  
TK P/N 44-6534  
Carrier P/N 20-44-6534



**Sensor, Radiator**  
TK P/N 41-1818  
Carrier P/N 20-41-1818



**Switch (On/Off)**  
TK P/N 41-1514  
Carrier P/N 20-41-1514



# Electrical

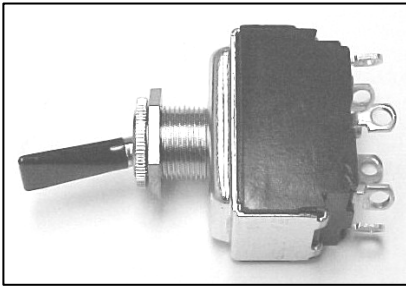

**Switch**  
TK P/N 44-7929  
Carrier P/N 20-44-7929

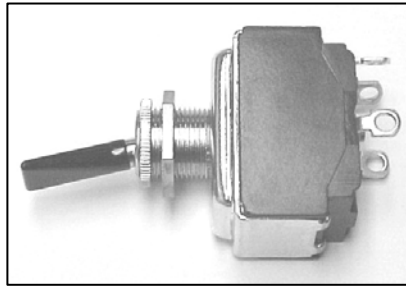

**Switch**  
TK P/N 44-7793  
Carrier P/N 20-44-7793

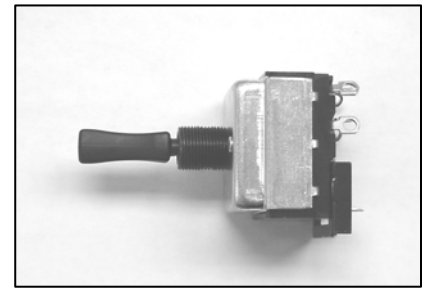

**Switch**  
TK P/N 44-7932  
Carrier P/N 20-44-7932

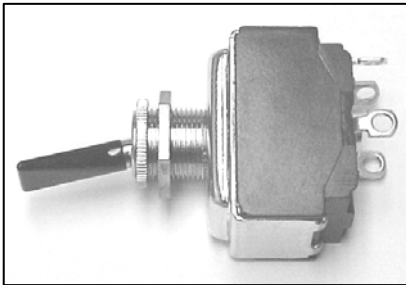

**Switch (On/Off)**  
TK P/N 44-7792  
Carrier P/N 20-44-7792



**Sensor, Oil Pressure**  
TK P/N 44-8883  
Carrier P/N 20-44-8883



**Switch (HPCO)**  
TK P/N 41-1608  
Carrier P/N 20-41-1608



**Oil Pressure Switch**  
TK P/N 44-4774  
Carrier P/N 20-44-4774



**Timer, F.S. & Unloader F.S.**  
TK P/N 44-8679  
Carrier P/N 20-44-8679

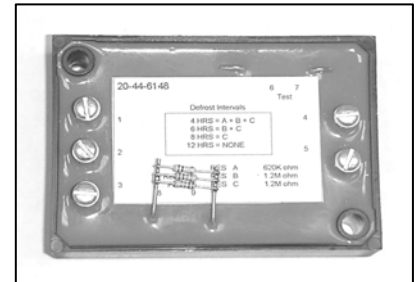

**Defrost Timer**  
TK P/N 44-6148  
Carrier P/N 20-44-6148

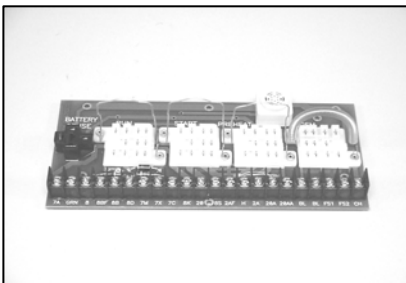

**Board (P.C. CS-II w/buzzer)**  
TK P/N 44-7246  
Carrier P/N 20-44-7246

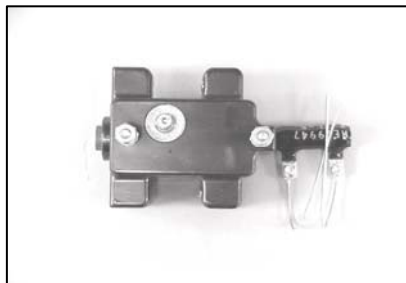

**Switch, Cutout/Reset**  
TK P/N 44-1659  
Carrier P/N 20-44-1659



**Solenoid (Fuel)**  
TK P/N 44-6727  
Carrier P/N 20-44-6727

# Electrical



**Relay, Starter**  
TK P/N 41-2794  
Carrier P/N 20-41-2794



**Timer (Defrost)**  
TK P/N 44-7531  
Carrier P/N 20-44-7531



**Switch (Starter Lockout)**  
TK P/N 44-7192  
Carrier P/N 20-44-7192



**RPM Sensor**  
TK P/N 44-9298  
Carrier P/N 20-44-9298

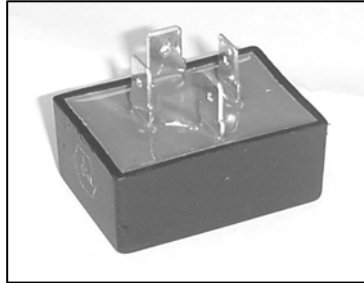

**Relay, Battery Sentry**  
TK P/N 44-6463  
Carrier P/N 20-44-6463

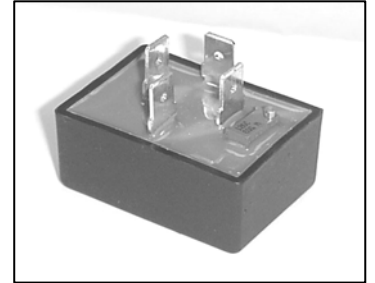

**Relay, Battery**  
TK P/N 44-8029  
Carrier P/N 20-44-8029

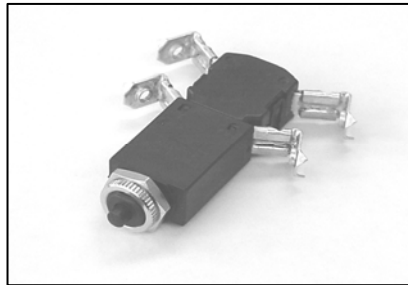

**Breaker, Circuit**  
TK P/N 44-7774  
Carrier P/N 20-44-7774



**Coil, Mod Valve**  
TK P/N 44-5175  
Carrier P/N 14-50021-02

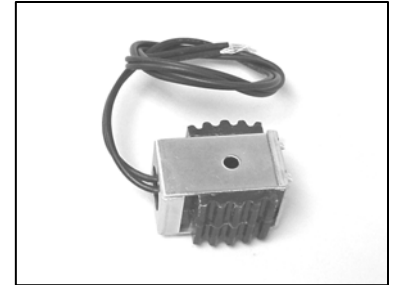

**Coil**  
TK P/N 44-3681  
Carrier P/N 20-44-3930

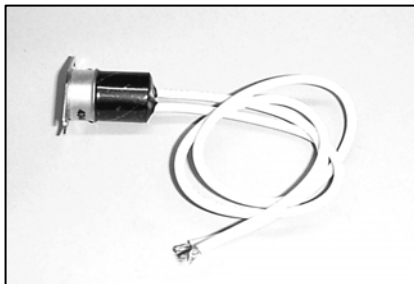

**Sensor, Temperature**  
TK P/N 44-6018  
Carrier P/N 20-44-6018

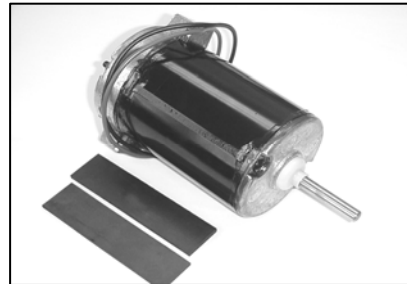

**Motor, 12V**  
TK P/N 44-8526  
Carrier P/N 20-44-8526

# Electrical

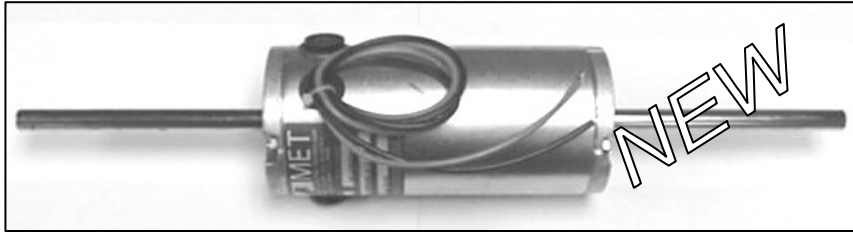

**Motor, 12V Dual Shaft**  
TK P/N 44-7172  
Carrier P/N 20-44-7172

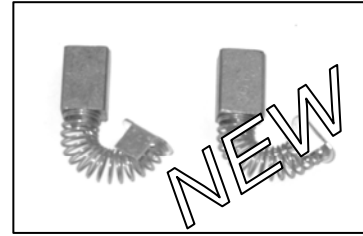

**Brushes, For 44-7172 motor**  
TK P/N 44-7050  
Carrier P/N 20-44-7050

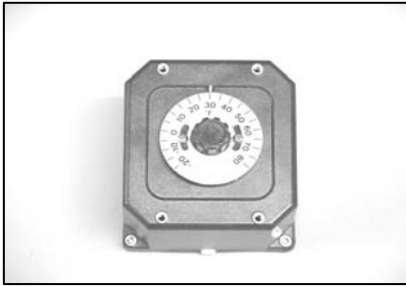

**Thermostat**  
TK P/N 45-1565  
Carrier P/N 20-45-1565

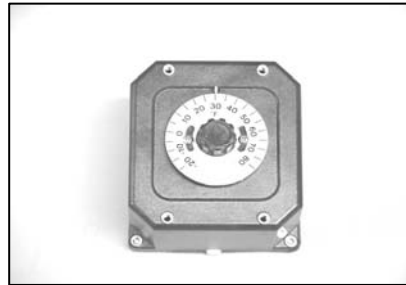

**Thermostat**  
TK P/N 45-1564  
Carrier P/N 20-45-1564



**Relay, Defrost**  
TK P/N 44-3186  
Carrier P/N 20-44-3186



**Probe Repair Kit For 3K Sensors**  
**Carrier P/N 12-50077-00**

This Kit Includes Everything You Need To Repair The Following Probes:

- 44-5234** (JD, KD, RD, TD, SB's, Super II, SNWD)
- 44-5236** (KD I, MD I, RD I, SB II, SNWD)
- 44-5569** (Super II Max w/2.2DI engine)
- 44-7674** (KD II, MD II, RD II, TD II, TS-500/600, Sentry, Super II, SB III)



DESCRIPTION	TK P/N	CTD P/N
Kit, C-201 engine rebuild .025	NA	20 10 C-201 025
Kit, C-201 engine rebuild .050	NA	20 10 C-201 050
Kit, C-201 engine rebuild .075	NA	20 10 C-201-075
Kit, C-201 engine rebuild std.	NA	20 10 C-201 STD
Bearing set, cam C-201	11 3845	20 11 3845
Bearing set, main C-201 std	11 4785	20 11 4785
Bearing set, main C-201 .25	11 4786	20 11 4786
Bearing set, main C-201 .50	11 4787	20 11 4787
Bearing set, main C-201 .75	11 4800	20 11 4800
Bearing set, rod C-201 std	11 5744	20 11 5744
Bearing set, rod C-201 .025	11 5745	20 11 5745
Bearing set, rod C-201 .050	11 5746	20 11 5746
Bearing set, rod C-201 .075	11 5747	20 11 5747
Boot, solenoid	99 1672	58 50006
Boss pulley	77 1366	20 11 1366
Camshaft, C-201	11 3431	20 11 3431
Check valve kit	11 6016	29 50052 50
Collar, split	11 2929	20 11 2929
Diode assy, run/speed solenoid	44 2756	22 01030 17
Eye bolt	55 2762	34 50009 00
Filter, screen	11 2854	25 38666 16
Freeze plugs, block C-201	10 258	20 10 258
Freeze plugs, head C-201	10 259	20 10 259
Fuel pump, w/prime C-201	11 3356	20 11 3356
Gasket	33 1121	20 33 1121
Gasket, front plate	33 1058	20 33 1058

# Engines

# Isuzu C-201

DESCRIPTION	TK P/N	CTD P/N
Gasket, head	33 792	20 33 792
Gasket, injection pump	33 714	20 33 714
Gasket, plug	33 653	20 33 653
Gasket, set, C-201 engine	30 175	20 30 175
Gasket, washer	33 796	20 33 796
Glow plug	44 2922	20 44 2922
Hose, by-pass	11 4564	20 11 4564
Hose, oil drain	11 3679	58 00615 01
Injector nozzle assy	11 4076	20 11 4076
Key	55 1600	30 00171 31
Nipple	11 2760	25 38666 08
Nozzle, injector, C-201	11 3365	20 11 3365
Oil pump	11 5338	20 11 5338
O-ring	33 1290	25 38666 09
O-ring, lift pump	33 1641	25 38667 00
O-ring, primer pump, aluminum	33 1653	25 38666 09
O-ring, valve cover	33 782	20 33 782
Piston	11 2923	25 38666 01
Piston assy, C-201 std	11 4848	20 11 4848
Piston assy, C-201 .25	11 4849	20 11 4849
Piston assy, C-201 .50	11 4850	20 11 4850
Piston assy, C-201 .75	11 5686	20 11 5686
Piston assy, C-201 1.00	11 4851	20 11 4851
Plug	55 1953	25 38666 03
Plunger assy	44 2847	34 50009 01
Ring set, C-201 std	11 4744	20 11 4744
Ring set, C-201 .50	11 4746	20 11 4746
Ring set, C-201 1.00	11 4747	20 11 4747
Ring, snap	55 1951	25 38666 10
Rocker arm, intake C-201	11 3441	20 11 3441
Rocker arm, exhaust C-201	11 3443	20 11 3443
Screw, hollow	55 1965	25 38666 14
Screw, hollow	55 5524	25 38666 12
Seal, front crankshaft, C-201	33 2881	20 33 2881
Seal, oil pan	33 799	20 33 799
Seal, rear crankshaft, C-201	33 2535	20 33 2535
Seal kit, C-201 rear	30 197	20 30 197
Sensor, rpm	44 6016	20 44 6016
Sensor, rpm	44 9298	20 44 9298
Sleeve, cylinder, C-201	11 5629	20 11 5629
Soft plug, cap sealing 18mm	11 3369	25 35077 00
Solenoid, starter	44 2911	20 44 2911
Solenoid, starter C-201 "Hitachi"	44 6424	20 44 6424
Speedi-sleeve, front	11 6845	20 11 6845
Speedi-sleeve, rear	11 7259	20 11 7259
Spring, check valve	11 2808	25 38666 07

# Engines

# Isuzu C-201

<b>DESCRIPTION</b>	<b>TK P/N</b>	<b>CTD P/N</b>
Spring, piston	11 2924	25 38666 02
Starter, Isuzu, C-201	45 1285	20 45 1285
Starter, Isuzu, C-201, remanufactured	845 1285	20 45 1285RM
Switch, oil safety	44 4774	20 44 4774
Switch, water temp safety	44 3018	20 44 3018
Tappet, C-201	11 3439	20 11 3439
Thrust washer set, C-201	11 3404	20 11 3404
Valve, exhaust, C-201	11 2719	20 11 2719
Valve, intake, C-201	11 2727	20 11 2727
Valve, guide inlet, C-201	11 3374 P04	20 11 3374
Valve, guide exhaust, C-201	11 3375 P04	20 11 3375
Valve seals	11 4414	20 11 4414
Washer, corrugated	55 3534	20 55 3534
Washer, fuel pipe	55 1922	25 38666 13
Washer, heatshield	55 3345	20 55 3345
Washer, nozzle	55 2459	20 55 2459
Washer, oil tube	33 1719	20 33 1719
Washer, piston chamber	33 1652	25 38666 04
Water pump, C-201	11 4576	20 11 4576

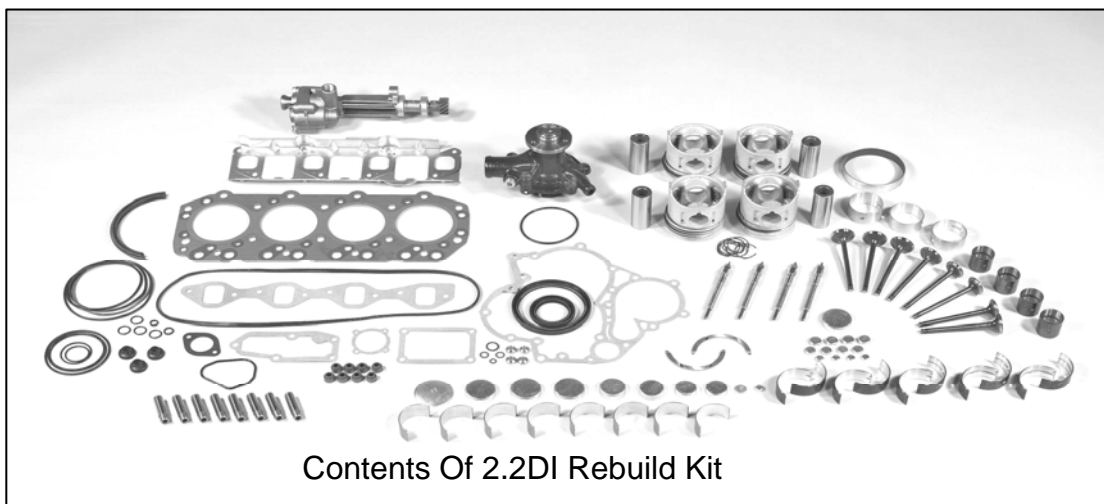

DESCRIPTION	TK P/N	CTD P/N
Kit, 2.2DI overhaul w/ Std. Pistons, Std. Bearings	NA	20 10 2.2DI STD
Kit, 2.2DI overhaul w/ 0.25 Pistons, Std. Bearings	NA	20 10 2.2DI 025
Kit, 2.2DI overhaul w/ 0.50 Pistons, Std. Bearings	NA	20 10 2.2DI 050
Bearing, rod, Isuzu 2.2 DI std	11 5826	20 11 5826
Bearing, rod Isuzu 2.2 DI 0.25	11 5827	20 11 5827
Bearing set, cam, Isuzu 2.2 DI	11 5785	20 11 5785
Bearing set, main Isuzu 2.2 DI	11 5806	20 11 5806
Bearing set, main Isuzu 2.2 DI .025	11 5807	20 11 5807
Check valve set	11 6016	29 50052 50
Fuel pump	11 7500	20 11 7500
Gasket set, 2.2 DI engine	30 177	20 30 177
Glow plug, 2.2 DI	44 6601	20 44 6601
Hose, bypass	11 5861	20 11 5861
Hose, oil drain	11 7821	20 11 7821
Oil pump, Isuzu 2.2 DI	11 6017	20 11 6017
O-ring, injector	33 1656	25 37599 00
O-ring, (used on 2.2 DI water pump)	33 1646	20 33 1646
O-ring, primer pump aluminum	33 1653	25 38666 09
Piston assy, 2.2 DI, STD	11 5900	20 11 5900
Piston assy, 2.2 DI, .25MM	11 5901	20 11 5901
Piston assy, 2.2 DI, .50MM	11 5902	20 11 5902
Pump, hand primer	11 5895	25 38666 11
Ring set, 2.2 DI, STD	11 8082	20 11 8082
Ring set, 2.2 DI, .25MM	11 8083	20 11 8083
Ring set, 2.2 DI, .50MM	11 8084	20 11 8084
Seal, crankshaft, front	33 2881	20 33 2881
Seal, crankshaft, rear	33 2880	20 33 2880
Sensor, rpm	44 9298	20 44 9298
Solenoid, starter, 2.2 DI "Hitachi"	44 6679	20 44 6679
Solenoid, fuel shutoff	44 6727	20 44 6727
Starter, Isuzu 2.2 DI	45 1993	20 45 1993

# Engines

## Isuzu 2.2

DESCRIPTION	TK P/N	CTD P/N
Starter, Isuzu 2.2 DI, remanufactured	845 1263	20 45 1263RM
Switch, engine water safety	44 3018	20 44 3018
Tappet	11 5887	25 38666 05
Thermostat, water	11 7702	25 10391 01
Thrust bearing set, Isuzu 2.2 DI	11 5811	20 11 5811
Valve guide, IN/EX Isuzu 2.2 DI	11 5779	20 11 5779
Valve, intake, Isuzu 2.2 DI	11 5850	20 11 5850
Valve, exhaust, Isuzu 2.2 DI	11 5851	20 11 5851
Water pump, 2.2 DI & SE	11 9356	20 11 9356
Wrist pin bushing, Isuzu 2.2 DI	11 5825	20 11 5825

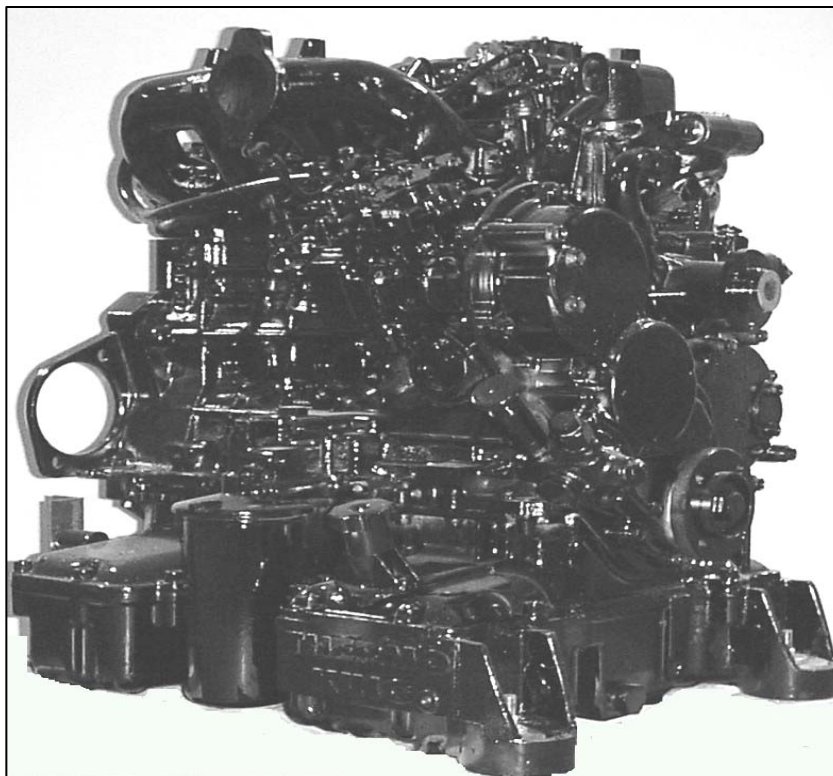

### Remanufactured 2.2 DI and SE 2.2 Engines

These engines are totally remanufactured. All wear items are replaced, and every injection pump is rebuilt to insure optimum performance and long life. These engines also come with a one year parts warranty.

#### 2.2 DI Reman Engine

Carrier P/N 20-10-1257RM

#### SE 2.2 Reman Engine Before S/N 992987

Carrier P/N 20-10-1282RM



# Engines

# Yanmar 2.35

<b>DESCRIPTION</b>	<b>TK P/N</b>	<b>CTD P/N</b>
Bearing, cam, front Yanmar	11 5028	20 11 5028
Bearing, front main, (ball) Yanmar	11 5481	20 11 5481
Bearing, main, added on 3 cylinder Yanmar	11 5182	20 11 5182
Bearing, main, front Yanmar	11 5003	20 11 5003
Bearing, main, rear Yanmar	11 5006	20 11 5006
Bearing, main, thrust Yanmar	11 5007	20 11 5007
Bearing, rod, std Yanmar	11 5043	20 11 5043
Gasket, water pump	33 1527	20 33 1527
Gasket kit, Yanmar	30 173	20 30 173
Glow plug, Yanmar, hose type	44 4728	20 44 4728
Guide, intake valve, Yanmar	11 5016	20 11 5016
Guide, exhaust valve, Yanmar	11 5017	20 11 5017
Injector valve assy	11 5051	20 11 7431
Oil pump assy	11 5488	20 11 5488
O-ring, rear main housing	33 1507	20 33 1507
Piston rings	11 5106	20 11 5106
Piston	11 5248	20 11 5248
Rocker arm shaft	11 5186	20 11 5186
Seal, rear oil	33 1506	20 33 1506
Sleeve, cylinder	11 5002	20 11 5002
Speedi-sleeve, Yanmar crank rear	11 5967	20 11 5967
Starter, Yanmar, 235 & 353	45 1251	20 45 1251
Starter, Yanmar, 235 & 353, remanufactured	845 1251	20 45 1251RM
Thermostat, gasket	33 1520	20 33 1520
Valve, intake, Yanmar	11 5011	20 11 5011
Valve, exhaust, Yanmar	11 5012	20 11 5012
Water pump, Yanmar 235 & 353	11 5436	20 11 5436
Wrist pin bushing	11 5459	20 11 5459

# Engines

# Yanmar 353

<b>DESCRIPTION</b>	<b>TK P/N</b>	<b>CTD P/N</b>
Bearing, cam, front Yanmar	11 5028	20 11 5028
Bearing, front main (ball) Yanmar	11 5481	20 11 5481
Bearing, main, added on 3 cylinder Yanmar	11 5182	20 11 5182
Bearing, main, front Yanmar	11 5003	20 11 5003
Bearing, main, rear Yanmar	11 5006	20 11 5006
Bearing, main, thrust Yanmar	11 5007	20 11 5007
Bearing, rod, std Yanmar	11 5043	20 11 5043
Gasket, thermostat	33 1520	20 33 1520
Gasket, water pump	33 1527	20 33 1527
Gasket kit, Yanmar	30 173	20 30 173
Glow plug, Yanmar hose type	44 4728	20 44 4728
Guide, intake valve, Yanmar	11 5016	20 11 5016
Guide, exhaust valve, Yanmar	11 5017	20 11 5017
Injector valve assy	11 5051	20 11 7431
Oil pump assy	11 5488	20 11 5488
Piston	11 5248	20 11 5248
Piston rings	11 5106	20 11 5106
Piston pin	11 5107	20 11 5107
Rocker arm shaft	11 5186	20 11 5186
Seal, rear oil	33 1506	20 33 1506
Sleeve	11 5002	20 11 5002
Speedi-sleeve, Yanmar crank, rear	11 5967	20 11 5967
Starter, Yanmar 235 & 353	45 1251	20 45 1251
Starter, Yanmar, 235 & 353, remanufactured	845 1251	20 45 1251RM
Valve, intake, Yanmar	11 5011	20 11 5011
Valve, exhaust, Yanmar	11 5012	20 11 5012
Wrist pin bushing	11 5459	20 11 5459

# Engines

# Yanmar 3.66

<b>DESCRIPTION</b>	<b>TK P/N</b>	<b>CTD P/N</b>
Bearing, camshaft	11 6033	20 11 6033
Bearing, connecting rod	11 6077	20 11 6077
Bearing, main	11 6026	20 11 6026
Gasket kit, 366 engine	30 180	20 30 180
Glow plug, Yanmar, 12 volt	44 7130	25 36482 01
Pin bushing (std)	11 6078	20 11 6078
Piston assy w/rings (std), 366 engine	11 7022	20 11 7022
Piston assy w/rings (.25MM o/s), 366 engine	11 7023	20 11 7023
Piston assy w/rings (.50MM o/s) 366 engine	11 7024	20 11 7024
Rings (std), 366 engine	11 6072	20 11 6072
Rings (.25MM o/s), 366 engine	11 6073	20 11 6073
Rings (.50MM o/s), 366 engine	11 6023	20 11 6023
Seal, rear oil	33 1506	20 33 1506
Starter, Yanmar, 366 & 388	45 1312	20 45 1312
Starter, Yanmar, 366 & 388, remanufactured	845 1312	20 45 1312RM
Thrust washer (std)	11 6028	20 11 6028
Valve, exhaust	11 6040	20 11 6040
Valve, intake	11 6039	20 11 6039
Valve guide	11 6038	20 11 6038
Valve stem seal	33 1732	20 33 1732
Water pump, 3.66 Yanmar	11 6090	20 11 6090

# Engines

# Yanmar 3.88

<b>DESCRIPTION</b>	<b>TK P/N</b>	<b>CTD P/N</b>
Bearing, camshaft	11 6976	20 11 6976
Bearing, connecting rod (std)	11 6607	20 11 6607
Bearing, main (std)	11 6557	20 11 6557
Gasket kit, 388 engine	30 241	20 30 241
Glow plug, Yanmar, 12 volt	44 7130	25 36482 01
Pin bushing (std)	11 6606	20 11 6606
Piston assy w/rings (std), 388 engine	11 7025	20 11 7025
Piston assy w/rings (.25MM o/s), 388 engine	11 7026	20 11 7026
Piston assy w/rings (.50MM o/s) 388 engine	11 7027	20 11 7027
Rings (std), 388 engine	11 6601	20 11 6601
Rings (.25MM o/s), 388 engine	11 6603	20 11 6603
Rings (.50MM o/s), 388 engine	11 6605	20 11 6605
Seal, rear oil	33 1506	20 33 1506
Starter, Yanmar 366 & 388	45 1312	20 45 1312
Starter, Yanmar, 366 & 388, remanufactured	845 1312	20 45 1312RM
Thrust washer (std)	11 6558	20 11 6558
Valve, exhaust	11 6569	20 11 6569
Valve guide	11 6574	20 11 6574
Valve, intake	11 6568	20 11 6568

# Filters

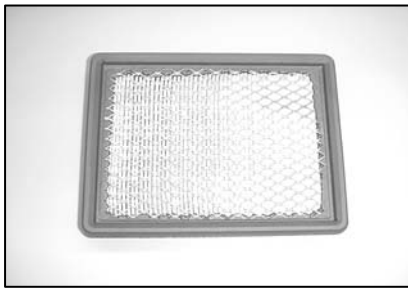

**Air Filter (Truck Units)**  
TK P/N 11-7234  
Carrier P/N 20-11-7234



**Air Filter (Trailer Units)**  
TK P/N 11-7400  
Carrier P/N 20-12-7400  
(case of 9 filters)



**Air Filter (Trailer Units)**  
TK P/N 11-9300  
Carrier P/N 20-12-9300  
(case of 12 filters)

## Replacement For TK's 11-9342 Fuel Water Separator

Why send water back to your fuel tank when you can remove it right at the filter. With Carrier's **20-11-9342C**, fuel water separators, you get a drain valve built into the filter sump so you can **easily** remove the water at pre-determined intervals. Just follow these easy steps:

- 1) STOP THE ENGINE
- 2) Unscrew the valve stem until water starts to flow.
- 3) Tighten the valve stem when all water has been removed.
- 4) Re-start engine

Because of these features, the filter is 2 inches longer than the OE filter (6-1/2" long overall). Check for proper clearance on your units before ordering.

### Features:

- Installs on existing fuel head
- Self venting drain
- Meets OE specifications
- Includes a handy drain interval label



**Compressor Oil Filter**  
TK P/N 66-4917  
Carrier P/N 20-66-4917



**Compressor Oil Filter**  
TK P/N 66-7800  
Carrier P/N 20-66-7800

We Also Have A Full Line Of Fuel & Oil Filters For Your Truck & Trailer Units. Just Go To The Cross Reference Section And Look It Up By TK Part Number .

# Filters

<b>DESCRIPTION</b>	<b>TK P/N</b>	<b>CTD P/N</b>
Filter, air	11 3331	66U1 2155
Filter, air cleaner, (dry)	11 7234	20 11 7234
Filter, air cleaner, (dry)	11 7400	20 12 7400
Filter, air cleaner, (dry), (case of 9)	12 7400	20 12 7400
Filter, bypass oil	11 6228	20 12 6228
Filter, bypass oil, (case of 12)	12 6228	20 12 6228
Filter, drivers heater	301 134	38 00515 00
Filter, fuel, primary, emi	11 9102	20 12 9102
Filter, fuel, primary, emi (case of 12)	12 9102	20 12 9102
Filter, fuel, primary, std	11 9097	20 12 9097
Filter, fuel, primary, std, (case of 12)	12 9097	20 12 9097
Filter, fuel, rectangle	11 6285	20 12 6285
Filter, fuel, rectangle (case of 12)	12 6285	20 12 6285
Filter, fuel, secondary	11 3068	30 00134 01
Filter, fuel, secondary emi	11 9103	20 12 9103
Filter, fuel, secondary emi (case of 12)	12 9103	20 12 9103
Filter, fuel, secondary std	11 9098	20 12 9098
Filter, fuel, secondary std (case of 12)	12 9098	20 12 9098
Filter, fuel, water separator rectangle	11 6286	20 12 6286
Filter, fuel, water separator rectangle (case of 12)	12 6286	20 12 6286
Filter, fuel, water separator rectangle	11 7264	20 12 7264
Filter, fuel, water separator rectangle (case of 12)	12 7264	20 12 7264
Filter, oil	11 4565	30 00303 00
Filter, oil, emi	11 9100	20 12 9100
Filter, oil, emi (case of 12)	12 9100	20 12 9100
Filter, oil, emi by-pass	11 5703	20 12 5703
Filter, oil, emi by-pass (case of 12)	12 5703	20 12 5703
Filter, oil, primary std	11 9099	20 12 9099
Filter, oil, primary std (case of 12)	12 9099	20 12 9099
Filter, Walboro fuel pump	11 4702	30 00106 06

# Hoses & Vibrasorbers

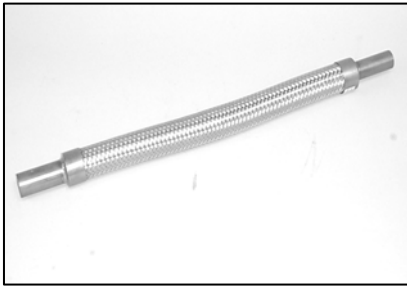

**Discharge Vibe (SB III's & SB II Max)**  
 TK P/N 66-5784  
 Carrier P/N 20-66-5784

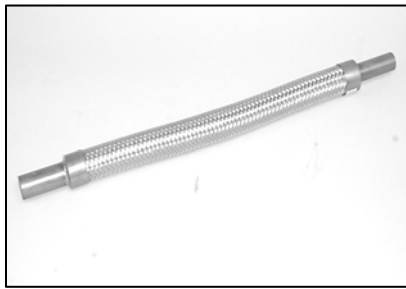

**Discharge Vibe (NWD, SNWD, SB I, SB II, RMU, TWD & KDI)**  
 TK P/N 66-1224  
 Carrier P/N 20-66-1224

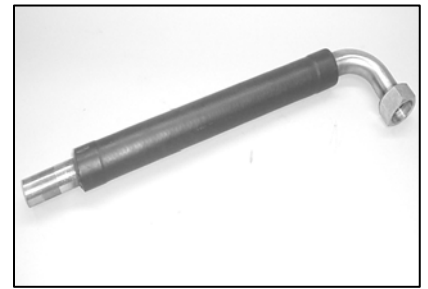

**Suction Vibe (SB II)**  
 TK P/N 66-4423  
 Carrier P/N 20-66-4423



**Suction Vibe (Super II Max)**  
 TK P/N 66-4990  
 Carrier P/N 20-66-4990



**Suction Vibe (SB II)**  
 TK P/N 66-4551  
 Carrier P/N 20-66-4551

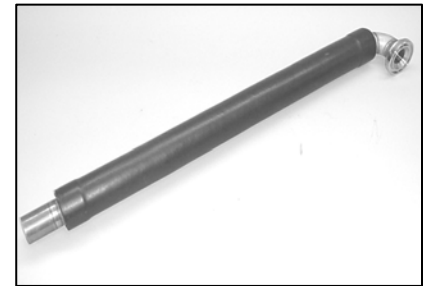

**Suction Vibe (Sentry)**  
 TK P/N 66-3994  
 Carrier P/N 20-66-3994

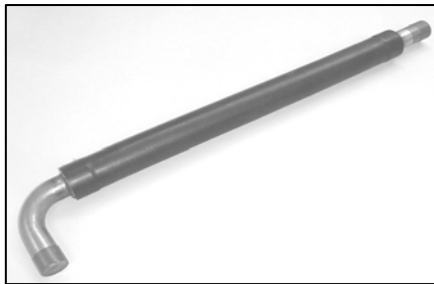

**Suction Vibe (Super II)**  
 TK P/N 66-5717  
 Carrier P/N 20-66-5717



**Suction Vibe (KD, RD, TD)**  
 TK P/N 66-3467  
 Carrier P/N 20-66-3467



**Suction Vibe (SB III & SB II)**  
 TK P/N 66-4884  
 Carrier P/N 20-66-4884

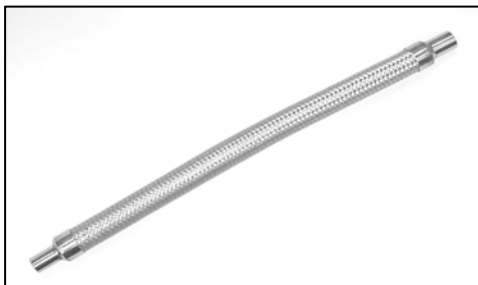

**Discharge Vibe (Super II)**  
 TK P/N 66-7848  
 Carrier P/N 20-66-7848



**Suction Vibe (SB II & SBIII)**  
 TK P/N 66-6024  
 Carrier P/N 20-66-6024



**Suction Vibe (SENTRY)**  
 TK P/N 66-3974  
 Carrier P/N 20-66-3974

## Hoses & Vibrasorbers

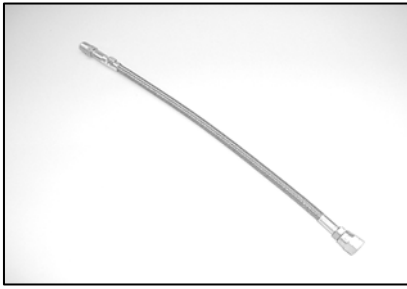

**Teflon Hose (12" Long)**  
TK P/N 66-5150  
Carrier P/N 20-66-5150



**Teflon Hose (18" Long)**  
TK P/N 66-4961  
Carrier P/N 20-66-4961



**Teflon Hose (40" Long)**  
TK P/N 66-5175  
Carrier P/N 20-66-5175



**Teflon Hose (21" Long)**  
TK P/N 66-7465  
Carrier P/N 20-66-7465



**Teflon Hose (11.25" Long)**  
TK P/N 66-5176  
Carrier P/N 20-66-5176



**Teflon Hose (33" Long)**  
TK P/N 66-5177  
Carrier P/N 20-66-5177



# Refrigeration

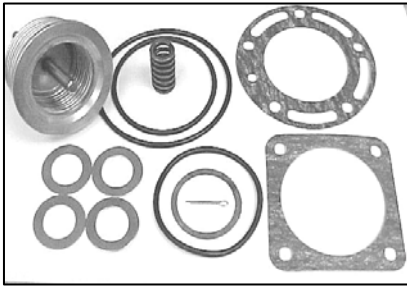

**Throttling Valve Repair Kit**  
TK P/N 60-107  
Carrier P/N 20-60-107



**3 Way Valve Screen Kit**  
TK P/N 60-147  
Carrier P/N 20-60-147

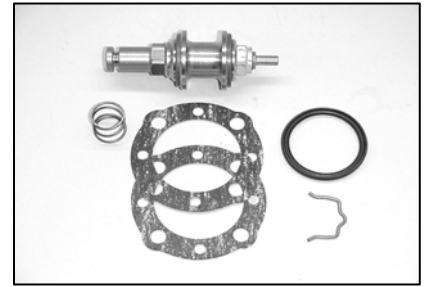

**3 Way Valve Stem Kit**  
TK P/N 60-156  
Carrier P/N 20-60-156

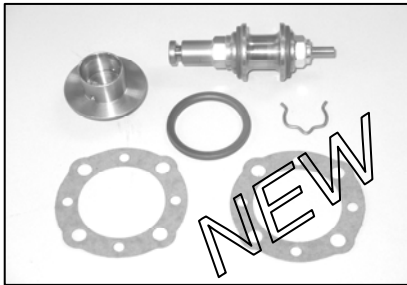

**3 Way Valve Stem Kit**  
TK P/N 60-283  
Carrier P/N 20-60-283



**Pilot Solenoid**  
TK P/N 66-7636  
Carrier P/N 20-66-7636



**Pilot Solenoid**  
TK P/N 66-5908  
Carrier P/N 20-66-5908



**Pilot Solenoid**  
TK P/N 66-2009  
Carrier P/N 20-66-2009



**Coil, 12V**  
TK P/N 41-1521  
Carrier P/N 20-41-1521

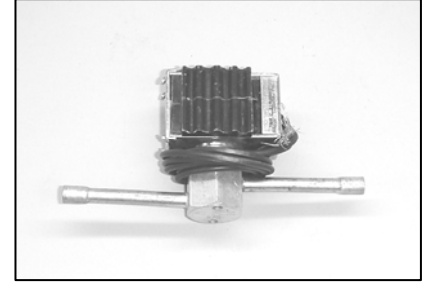

**Solenoid Valve**  
TK P/N 66-5374  
Carrier P/N 20-66-5374



**Modulation Valve Repair Kit**  
TK P/N 60-203  
Carrier P/N 20-60-203  
**Repairs The Following Valves:**  
66-3943 (RD II & TD II Max)  
66-4767 (SB III, Super II)  
66-6911 (SB III Max, Whisper)  
66-7302 (LND)



**Coil, 12V**  
TK P/N 41-1525  
Carrier P/N 41-1525

# Refrigeration

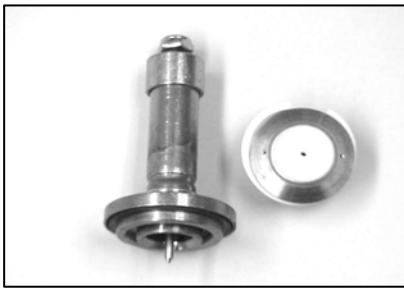

## Solenoid Valve Repair Kit

TK P/N 60-186

Carrier P/N 20-60-186

### Repairs The Following Valves:

66-6127 (MD II, RD II, Super II, SB III)

66-6140 (RD II)

66-7373 (MD II, RD II, Super II, SB III)

66-8695 (MD II)

66-8890 (MD II, RD II, Super II, SB III)

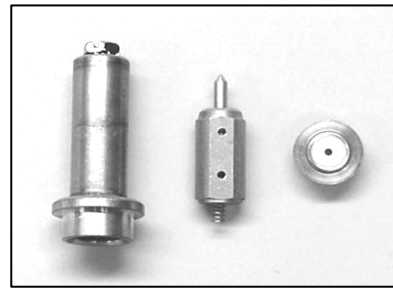

## Solenoid Valve Repair Kit

TK P/N 60-181

Carrier P/N 20-60-181

### Repairs The Following Valves:

66-2859 (MD II, RD II, Super II, SB III)

66-5305 (MD II, RD II, Super II, SB III)

66-6102 (MD II, RD II, Super II, SB III)

66-6384 (MD II, RD II, Super II, SB III)

66-8021

# Filter Driers

DESCRIPTION	TK P/N	CTD P/N
Filter	66 8473	20 66 8473
Filter drier	66 508	14 50030 00
Filter drier	66 814	14 01063 03
Filter drier	66 1409	14 50033 00
Filter drier	66 1723	14 01105 00
Filter drier	66 4729	14 50033 00
Filter drier	66 4857	14 50031 00
Filter drier	66 4858	14 50032 00
Filter drier	66 8767	20 66 8767
Filter drier	66 4900	14 50034 00
Filter drier (10 pack)	67 4729	14 50033 00
Filter drier (10 pack)	67 4900	14 50034 00
Filter drier, 10 pk	66 9700	20 67 9700
Filter drier, 41 cu.in. Ors	66 9200	20 68 600
Filter, compressor oil	66 4917	20 66 4917
Filter drier	68 600	20 68 600

# Starters



## Starter (C201)

TK P/N (new) 45-1285  
 Carrier P/N (new) 20-45-1285  
 Carrier P/N (reman) 20-45-1285RM

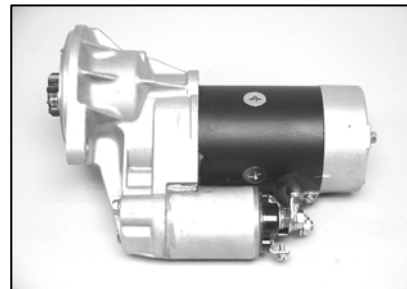

## Starter (2.2DI)

TK P/N (new) 45-1993  
 Carrier P/N (new) 20-45-1993  
 Carrier P/N (reman) 20-45-1263RM

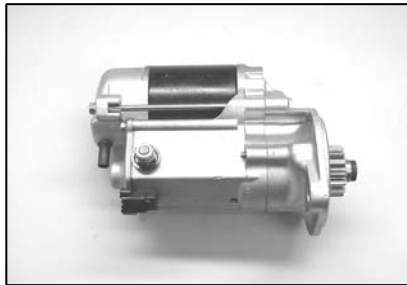

## Starter (366/374/388/395 Yanmar)

TK P/N (new) 45-1718  
 Carrier P/N (new) 20-45-1718  
 Carrier P/N (reman) 20-45-1312RM

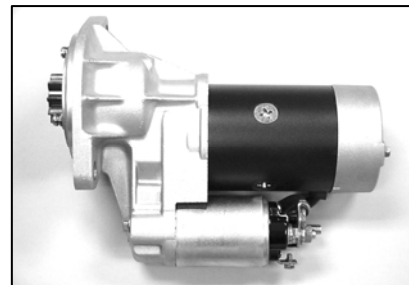

## Starter (Yanmar 486)

TK P/N (new) 45-1688  
 Carrier P/N (new) 20-45-1688

Our New And Remanufactured Starters Come  
 With An Extended Warranty. Contact Your Local  
 Carrier Transicold Dealer For Details.

DESCRIPTION	TK P/N	CTD P/N
Solenoid, starter 2.2 DI "Hitachi"	44 6679	20 44 6679
Solenoid, starter, C-201 "Hitachi"	44 6424	20 44 6424
Solenoid, starter, C-201 direct drive	44 2911	20 44 2911
Starter, Heat King II, JDII, CDII Max	845 1724	20 45 1724RM
Starter, Isuzu 2.2 DI	45 1671	20 45 1993
Starter, Isuzu 2.2 DI	45 1993	20 45 1993
Starter, Isuzu 2.2 DI, remanufactured	845 1263	20 45 1263RM
Starter, Isuzu C-201	45 1285	20 45 1285
Starter, Isuzu C-201, remanufactured	845 1285	20 45 1285RM
Starter, Yanmar 235 & 353	45 1251	20 45 1251
Starter, Yanmar 235 & 353, remanufactured	845 1251	20 45 1251RM
Starter, Yanmar 366/374/388/395	45 1718	20 45 1718
Starter, remanufactured, Yanmar 366/374/388/396	845 1312	20 45 1312RM
Starter, Yanmar 486 engine	45 1688	20 45 1688

# Miscellaneous

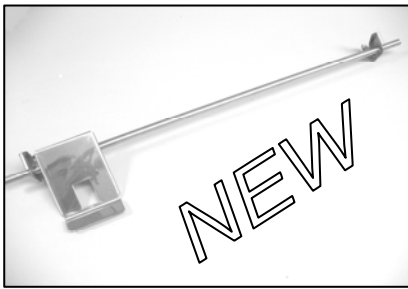

**Latch, Door**  
TK P/N 91-9621  
Carrier P/N 20-91-9621



**Lock, Door**  
TK P/N 91-188  
Carrier P/N 20-91-188



**Exhaust tube**  
TK P/N 11-7985  
Carrier P/N 20-11-7985



**Muffler, truck units**  
TK P/N 12-765  
Carrier P/N 20-12-765



**Hose, oil drain**  
TK P/N 11-7821  
Carrier P/N 20-11-7821

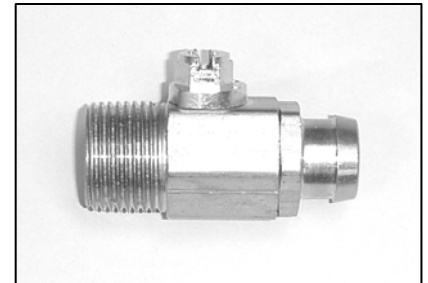

**Valve, oil drain**  
TK P/N 11-9338  
Carrier P/N 20-11-9338



**Hose, coolant**  
TK P/N 11-9529  
Carrier P/N 20-11-9529



**Hose, coolant**  
TK P/N 11-5909  
Carrier P/N 20-11-5909

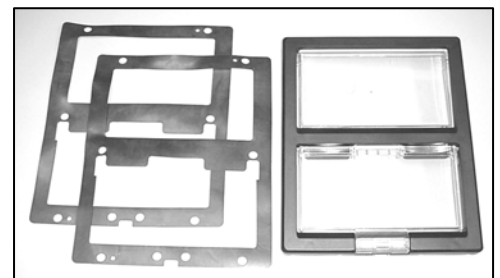

**Bezel, Micro**  
TK P/N 91-9303  
Carrier P/N 20-91-9303



**Guide, Belt**  
TK P/N 91-1199  
Carrier P/N 20-91-1199

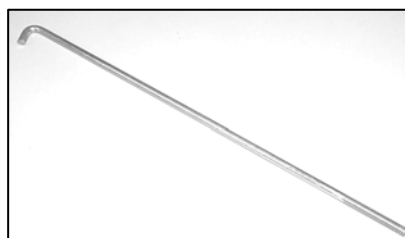

**Rod, battery hold down**  
TK P/N 99-4482  
Carrier P/N 20-99-4482

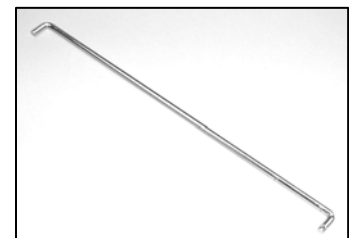

**Rod, solenoid linkage**  
TK P/N 99-8555  
Carrier P/N 20-99-8555

# Miscellaneous

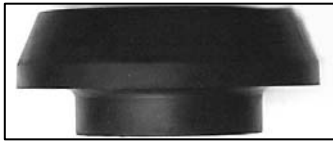

**Engine mount**  
TK P/N 99-1433  
Carrier P/N 20-99-1433

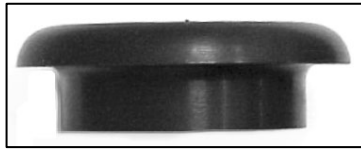

**Engine mount**  
TK P/N 99-1916  
Carrier P/N 20-99-1916

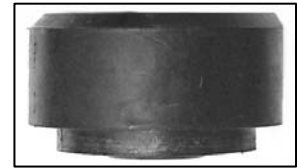

**Engine mount**  
TK P/N 91-4159  
Carrier P/N 20-91-4159

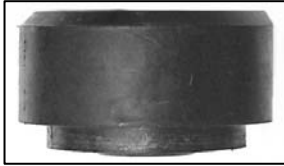

**Engine mount, Soft**  
TK P/N 91-2619  
Carrier P/N 20-91-2619



**Damper, door**  
TK P/N 99-6565  
Carrier P/N 20-99-6565



**Bearing**  
TK P/N 77-1070  
Carrier P/N 20-77-1070



**Dipstick, fuel**  
TK P/N 11-7486  
Carrier P/N 20-11-7486



**Switch, oil level**  
TK P/N 41-402  
Carrier P/N 20-41-402SV



**Grommet, oil level sensor**  
TK P/N 33-3877  
Carrier P/N 20-33-3877

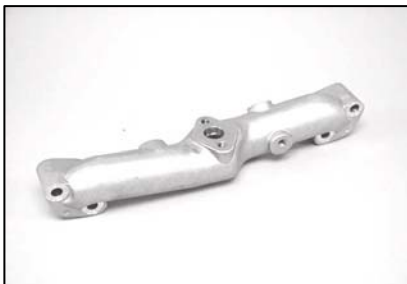

**Manifold, discharge**  
TK P/N 22-660  
Carrier P/N 20-22-660

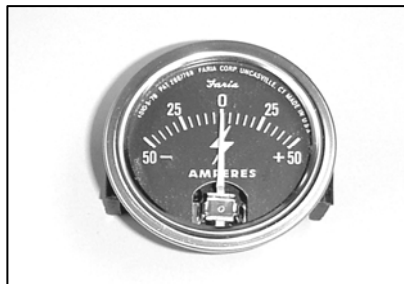

**Meter, amp**  
TK P/N 44-9302  
Carrier P/N 20-44-9302



**Pressure Relief Valve**  
TK P/N 66-7392  
Carrier P/N 20-66-7392

# Water Pumps

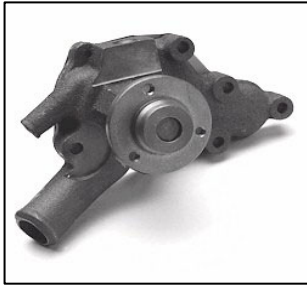

**Water Pump, C201**  
TK P/N 11-4576  
Carrier P/N 20-11-4576SV



**Water Pump, 235/353**  
TK P/N 11-9498  
Carrier P/N 20-11-5436

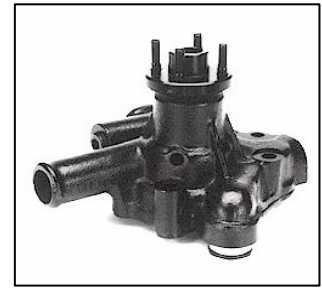

**Water Pump, 366**  
TK P/N 11-9496  
Carrier P/N 20-11-6090



**Water Pump, 2.2DI**  
TK P/N 11-9356  
Carrier P/N 20-11-9356

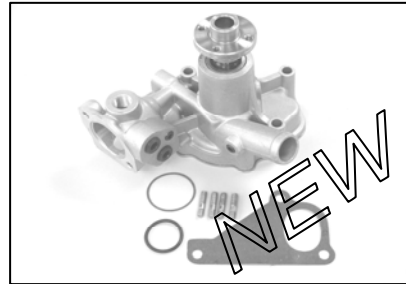

**Water Pump, 486 (Low)**  
TK P/N 11-9499  
Carrier P/N 20-11-9499

# Rebuilt Electronics

DESCRIPTION	TK P/N	CTD P/N
3K Thermostat	45 935	20 45 0935RB
3K Thermostat	45 0954	20 45 0954RB
3K Thermostat	45 1001	20 45 1001RB
3K Thermostat	45 1002	20 45 1002RB
3K Thermostat	45 1003	20 45 1003RB
3K Thermostat	45 1055	20 45 1055RB
3K Thermostat	45 1071	20 45 1071RB
3K Thermostat	45 1083	20 45 1083RB
3K Thermostat	45 1084	20 45 1084RB
3K Thermostat	45 1085	20 45 1085RB
3K Thermostat	45 1086	20 45 1086RB
3K Thermostat	45 1087	20 45 1087RB
3K Thermostat	45 1135	20 45 1135RB
3K Thermostat	45 1375	20 45 1375RB
MicroP 4 Controller	45 1440	20 45 1440RB
MicroP 4 Controller	45 1441	20 45 1441RB
MicroP 4 Controller	45 1511	20 45 1511RB
MicroP 4 Controller	45 1512	20 45 1512RB
MicroP 4 Controller	45 1517	20 45 1517RB
MicroP 4 Controller	45 1520	20 45 1520RB
MicroP 4 Controller	45 1521	20 45 1521RB
MicroP 4 Controller	45 1524	20 45 1524RB
MicroP 4 Controller	45 1557	20 45 1557RB
MicroP 4 Controller	45 1558	20 45 1558RB
MicroP 4 Controller	45 1570	20 45 1570RB
MicroP 4 Controller	45 1596	20 45 1596RB
MicroP 4 Controller	45 1597	20 45 1597RB
MicroP 4+ Controller	45 1600	20 45 1600RB
MicroP 4+ Controller	45 1601	20 45 1601RB
MicroP 4 Rail Unit Relay Board	45 1676	20 45 1676RB
MicroP 4 Relay Board	41 0737	20 41 0737RB
MicroP 4 Relay Board	41 1155	20 41 1155RB
MicroP 4 Relay Board	44 9468	20 44 9468RB
MicroP 6 Controller	45 1841	20 45 1841RB
MicroP 6 Controller	45 1930	20 45 1930RB

OUR REBUILT MICRO'S COME WITH A ONE YEAR WARRANTY. CALL YOUR LOCAL CARRIER TRANSICOLD DEALER FOR DETAILS



World Headquarters  
Carrier Transport Refrigeration & Air Conditioning  
Replacement Components Group  
P.O. Box 4805  
Syracuse, NY 13221 USA  
Tel: 800-255-7382  
Fax: 315-432-3778

A member of the United Technologies Corporation family.  
Stock symbol UTX.

\*TK is a trademark of Thermo King Corporation.